**Cardiovascular implants — Cardiac valve
prostheses**

Implants cardiovasculaires — Prothèses valvulaires

PDF disclaimer

This PDF file may contain embedded typefaces. In accordance with Adobe's licensing policy, this file may be printed or viewed but shall not be edited unless the typefaces which are embedded are licensed to and installed on the computer performing the editing. In downloading this file, parties accept therein the responsibility of not infringing Adobe's licensing policy. The ISO Central Secretariat accepts no liability in this area.

Adobe is a trademark of Adobe Systems Incorporated.

Details of the software products used to create this PDF file can be found in the General Info relative to the file; the PDF-creation parameters were optimized for printing. Every care has been taken to ensure that the file is suitable for use by ISO member bodies. In the unlikely event that a problem relating to it is found, please inform the Central Secretariat at the address given below.

© ISO 2005

All rights reserved. Unless otherwise specified, no part of this publication may be reproduced or utilized in any form or by any means, electronic or mechanical, including photocopying and microfilm, without permission in writing from either ISO at the address below or ISO's member body in the country of the requester.

ISO copyright office
Case postale 56 • CH-1211 Geneva 20
Tel. + 41 22 749 01 11
Fax + 41 22 749 09 47
E-mail copyright@iso.org
Web www.iso.org

Published in Switzerland

Contents

Page

Foreword.....	v
Introduction	vi
1 Scope.....	1
2 Normative references	1
3 Terms and definitions	2
4 Abbreviations	10
5 Fundamental requirements	11
6 Device description	11
6.1 Intended use	11
6.2 Design inputs	11
6.2.1 Operational specifications	11
6.2.2 Performance specifications	11
6.2.3 Packaging, labelling, and sterilization	12
6.3 Design outputs	13
6.3.1 General	13
6.3.2 Examples of components of some heart valve substitutes	13
6.4 Design transfer (manufacturing qualification).....	14
6.5 Risk management	14
6.5.1 Hazard identification.....	14
6.5.2 Failure mode identification	14
6.5.3 Risk estimation.....	15
6.5.4 Risk evaluation.....	15
6.5.5 Risk control	15
6.5.6 Risk review	15
7 Verification testing and analysis/Design validation	15
7.1 General requirements	15
7.2 <i>In vitro</i> assessment.....	16
7.2.1 Test conditions, sample selection and reporting requirements	16
7.2.2 Material property assessment	16
7.2.3 Hydrodynamic performance assessment.....	17
7.2.4 Structural performance assessment.....	18
7.3 Preclinical <i>in vivo</i> evaluation	19
7.3.1 Overall requirements	19
7.3.2 Methods.....	20
7.3.3 Test report.....	20
7.4 Clinical investigation	21
7.4.1 Principle	21
7.4.2 General	21
7.4.3 Number of institutions	21
7.4.4 Number of patients	21
7.4.5 Duration of the study	22
7.4.6 Clinical data requirements	22
7.4.7 Clinical investigation report.....	24
Annex A (informative) Rationale for the provisions of this International Standard	26
Annex B (informative) Heart valve substitute hazards, associated failure modes and evaluation methods	29
Annex C (informative) Risk assessment guidelines	31

Annex D (informative) Examples and definitions of some physical and material properties of heart valve substitutes and their components	38
Annex E (informative) Statistical procedures when using performance criteria	43
Annex F (informative) <i>In vitro</i> procedures for testing unstented or similar valves in compliant chambers	44
Annex G (informative) Preclinical <i>in vivo</i> tests.....	46
Annex H (informative) Echocardiographic protocol.....	49
Annex I (informative) Description of the heart valve substitute.....	52
Annex J (informative) Figures of examples of components of some heart valve substitutes	54
Annex K (informative) Examples of standards applicable to testing of materials and components of some heart valve substitutes.....	57
Annex L (informative) Guidelines for verification of hydrodynamic performance	63
Annex M (informative) Durability testing	69
Annex N (informative) Examples of design specific testing.....	71
Annex O (informative) Fatigue assessment	73
Annex P (normative) Packaging	77
Annex Q (normative) Labelling and instructions for use	78
Annex R (normative) Methods of evaluating clinical data.....	80
Annex S (normative) Sterilization	82
Bibliography.....	83

Foreword

ISO (the International Organization for Standardization) is a worldwide federation of national standards bodies (ISO member bodies). The work of preparing International Standards is normally carried out through ISO technical committees. Each member body interested in a subject for which a technical committee has been established has the right to be represented on that committee. International organizations, governmental and non-governmental, in liaison with ISO, also take part in the work. ISO collaborates closely with the International Electrotechnical Commission (IEC) on all matters of electrotechnical standardization.

International Standards are drafted in accordance with the rules given in the ISO/IEC Directives, Part 2.

The main task of technical committees is to prepare International Standards. Draft International Standards adopted by the technical committees are circulated to the member bodies for voting. Publication as an International Standard requires approval by at least 75 % of the member bodies casting a vote.

Attention is drawn to the possibility that some of the elements of this document may be the subject of patent rights. ISO shall not be held responsible for identifying any or all such patent rights.

ISO 5840 was prepared by Technical Committee ISO/TC 150, *Implants for surgery*, Subcommittee SC 2, *Cardiovascular implants and extracorporeal systems*.

This fourth edition cancels and replaces the third edition (ISO 5840:1996), which has been technically revised to include risk management.

Introduction

There is, as yet, no heart valve substitute that can be regarded as ideal.

This International Standard has been prepared by a group well aware of the problems associated with heart valve substitutes and their development. In several areas, the provisions of this International Standard have been deliberately left open as there has been no wish to inhibit development and innovation. It does specify types of tests, test methods and/or requirements for test apparatus, and requires documentation of test methods and results. The areas with which this International Standard is concerned are those which will ensure that associated risks to the patient and other users of the device have been adequately mitigated, facilitate quality assurance, aid the surgeon in choosing a heart valve substitute, and ensure that the device will be presented at the operating table in a convenient form. Emphasis has been placed on specifying types of *in vitro* testing, on preclinical *in vivo* and clinical evaluations, on reporting of all *in vitro*, preclinical *in vivo* and clinical evaluations and on the labelling and packaging of the device. Such a process involving *in vitro*, preclinical *in vivo* and clinical evaluations is intended to clarify the required procedures prior to market release and to enable prompt identification and management of any subsequent problems.

With regard to *in vitro* testing and reporting, apart from basic material testing for mechanical, physical, chemical and biocompatibility characteristics, this International Standard also covers important hydrodynamic and durability characteristics of heart valve substitutes. The exact test methods for hydrodynamic and durability testing have not been specified, but guidelines for the test apparatus are given.

This International Standard is incomplete in several areas. It is intended to be revised, updated, and/or amended, as knowledge and techniques in heart valve substitute technology improve.

Annexes A to S provide supplementary information, the content of Annexes P to S being necessary for the application of this International Standard.

Cardiovascular implants — Cardiac valve prostheses

1 Scope

1.1 This International Standard is applicable to all devices intended for implantation in human hearts, as a heart valve substitute.

1.2 This International Standard is applicable to both newly developed and modified heart valve substitutes and to the accessory devices, packaging and labelling required for their implantation and for determining the appropriate size of heart valve substitute to be implanted.

1.3 This International Standard outlines an approach for qualifying the design and manufacture of a heart valve substitute through risk management. The selection of appropriate qualification tests and methods are derived from the risk assessment. The tests may include those to assess the physical, chemical, biological and mechanical properties of heart valve substitutes and of their materials and components. The tests may also include those for pre-clinical *in vivo* evaluation and clinical evaluation of the finished heart valve substitute.

1.4 This International Standard imposes design specifications and minimum performance specifications for heart valve substitutes where adequate scientific and/or clinical evidence exists for their justification.

1.5 This International Standard excludes heart valve substitutes designed for implantation in artificial hearts or heart assist devices.

NOTE A rationale for the provisions of this International Standard is given in Annex A.

2 Normative references

The following referenced documents are indispensable for the application of this document. For dated references, only the edition cited applies. For undated references, the latest edition of the referenced document (including any amendments) applies.

ISO 8601:2000, *Data elements and interchange formats — Information interchange — Representation of dates and times*

ISO 10993-1:1997, *Biological evaluation of medical devices — Part 1: Evaluation and testing*

ISO 10993-2:1992, *Biological evaluation of medical devices — Part 2: Animal welfare requirements*

ISO 11134:1994, *Sterilization of health care products — Requirements for validation and routine control — Industrial moist heat sterilization*

ISO 11135:1994, *Medical devices — Validation and routine control of ethylene oxide sterilization*

ISO 11137:1995, *Sterilization of health care products — Requirements for validation and routine control — Radiation sterilization*

ISO 11607:2003, *Packaging for terminally sterilized medical devices*

ISO 13485, *Medical devices — Quality management systems — Requirements for regulatory purposes*

ISO 14155-1:2003, *Clinical investigation of medical devices for human subjects — Part 1: General requirements*

ISO 14160, *Sterilization of single-use medical devices incorporating materials of animal origin — Validation and routine control of sterilization by liquid chemical sterilants*

ISO 14630:—¹⁾, *Non-active surgical implants — General requirements*

ISO 14937:2000, *Sterilization of health care products — General requirements for characterization of a sterilizing agent and the development, validation and routine control of a sterilization process for medical devices*

ISO 14971:2000, *Medical devices — Application of risk management to medical devices*

EN 12442-1, *Animal tissues and their derivatives utilized in the manufacture of medical devices — Part 1: Analysis and management of risk*

EN 12442-2, *Animal tissues and their derivatives utilized in the manufacture of medical devices — Part 2: Controls on sourcing, collection and handling*

EN 12442-3, *Animal tissues and their derivatives utilized in the manufacture of medical devices — Part 3: Validation of the elimination and/or inactivation of viruses and transmissible agents*

Guidelines for reporting morbidity and mortality after cardiac valvular operations, American Association for Thoracic Surgery, European Association for Cardiothoracic Surgery, Society of Thoracic Surgeons, *Annals of Thoracic Surgery*, **62**, pp. 932-935, 1996

3 Terms and definitions

For the purposes of this document, the following terms and definitions apply.

3.1

accessories

device-specific tools that are required to assist in the implantation of the heart valve substitute

3.2

actuarial

statistical technique for estimating survival curves prior to the death of the last member of a cohort

NOTE Some examples are the “Kaplan-Meier” technique and the “life-table” technique.

3.3

anticoagulant-related haemorrhage

internal or external bleeding that causes death or stroke, or that requires transfusion, operation or hospitalization

NOTE This definition is restricted to patients who are receiving anticoagulants and/or antiplatelet drugs, and excludes minor bleeding events.

3.4

arterial diastolic pressure

minimum value of the arterial pressure during diastole

3.5

arterial peak systolic pressure

maximum value of the arterial pressure during systole

1) To be published. (Revision of ISO 14630:1997)

3.6**back pressure**

differential pressure applied across the closed valve

3.7**blood-equivalent fluid**

fluid whose physical properties, e.g. specific gravity, viscosity, approximate those of blood

3.8**closing volume**

component of the regurgitant volume that is associated with the dynamics of valve closure during a single cycle

See Figure 1.

3.9**control valve**

heart valve substitute for preclinical and clinical evaluations of similar design and constructed of similar material as the investigational device

NOTE The control valve should have a known clinical history.

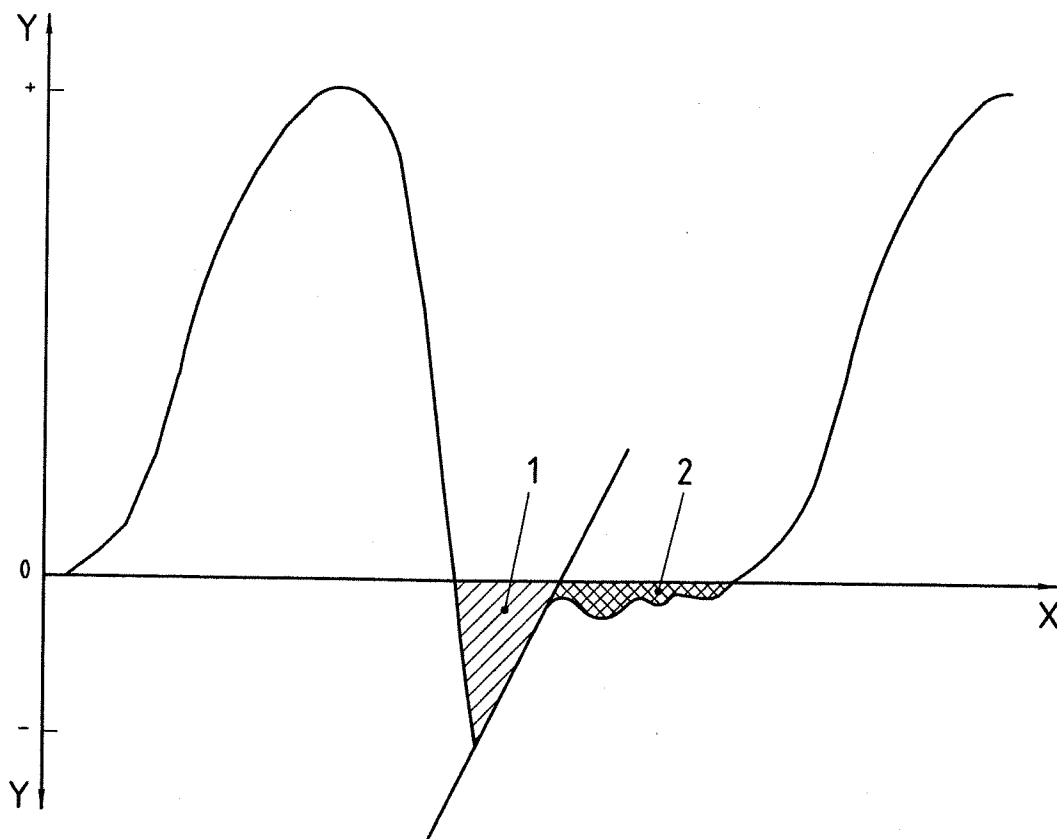
**Key**

X time

Y flowrate

1 closing volume

2 leakage volume

Figure 1 — Schematic representation of flow waveform and regurgitant volumes for one cycle

3.10

cumulative incidence

statistical technique where events other than death can be described by the occurrence of the event over time without including death of the subjects

NOTE Cumulative incidence is also known as 'actual' analysis.

3.11

cycle

one complete sequence in the action of a heart valve substitute under pulsatile-flow conditions

3.12

cycle rate

number of complete cycles per unit of time, usually expressed as cycles per minute (cycles/min)

3.13

design verification

establishment by objective evidence that the design output meets the design input requirements

3.14

design validation

establishment by objective evidence that device specifications conform with user needs and intended use(s)

3.15

effective orifice area

A_{EO}
orifice area that has been derived from flow and pressure or velocity data

3.16

failure

inability of a device to perform its intended function at any point during its intended lifetime

NOTE The inability to perform the intended function may manifest itself as a reduced operating effectiveness and/or as hazards.

3.17

failure mode

mechanism of failure which can result in a hazard

NOTE Stent fracture, calcification and prolapse are examples of failure modes.

3.18

flexible heart valve substitute

heart valve substitute wherein the occluder is flexible under physiological conditions

NOTE The orifice ring may or may not be flexible. This category was previously known as biological heart valve substitute because of the biological source of the flexible occluder(s) but, at a minimum, should also include flexible polymer occluder(s).

3.19

forward-flow phase

portion of the cycle time during which forward flow occurs through a heart valve substitute

3.20

hazard

known or potential source of harm which results from a given failure mode

3.21**harm**

physical injury or damage to the health of the patient or end-user of the device

NOTE Adapted from ISO/IEC Guide 51:1999 [14], definition 3.3.

3.22**heart valve substitute**

device used to replace or supplement a natural valve of the heart

See also 3.18 and 3.48, and examples in Figures J.1, J.2, J.3, J.4 and J.5.

3.23**intended use**

use of a product, process or service in accordance with the specifications, instructions and information provided by the manufacturer

3.24**internal orifice area****IOA**

numerical indication of the area within a prosthetic heart valve through which blood flows

See Figure 2.

3.25**intra-annular sewing ring**

sewing ring designed to secure the heart valve wholly or mostly within the patient's tissue annulus

See Figure 2. See also 3.24, 3.66 and 3.70.

3.26**intrasupra-annular sewing ring**

sewing ring designed to secure a portion of the valve or sewing ring above the patient's tissue annulus and also some portion of the valve within the patient's tissue annulus

See Figure 2. See also 3.24, 3.66 and 3.70.

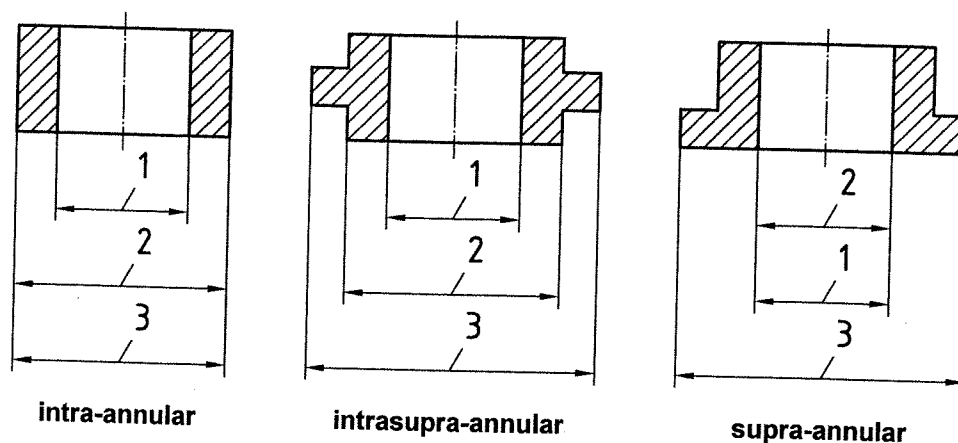
**Key**

- 1 IOA
- 2 TAD
- 3 ESRD

Figure 2 — Designation of dimensions of heart valve substitute sewing ring configurations

3.27
isolated (aortic or mitral) heart valve substitute
implantation of single heart valve substitute excluding patients who have a second heart valve substitute in a different anatomical position

NOTE Concomitant procedures, including valve repair, coronary artery bypass, and ascending aortic aneurysm repair, are not relevant to this definition. See 7.4.4.

3.28
leakage volume
component of the regurgitant volume which is associated with leakage through the closed valve during a single cycle

NOTE The point of separation between the closing and leakage volumes is obtained according to a defined and stated criterion (the linear extrapolation shown in Figure 1 is just an example).

3.29
linearized rate
linearized rate for a complication is the total number of events divided by the total time under evaluation

NOTE Generally, the rate is expressed in terms of percent per patient year.

3.30
long term follow-up
continued (after regulatory approval) periodic assessment of patients who have received the heart valve substitute during the clinical evaluation

3.31
manufacturer
organization with responsibility for the design, manufacture, packaging or labelling of a medical device, assembling a system, or adapting a medical device before it is placed on the market, regardless of whether these operations are carried out by the organization or on their behalf by a third party

3.32
mean arterial pressure
time-averaged arithmetic mean value of the arterial pressure during one cycle

3.33
mean pressure difference
time-averaged arithmetic mean value of the pressure difference across a heart valve substitute during the forward-flow phase of the cycle

NOTE The use of "mean pressure gradient" for this term is deprecated.

3.34
nonstructural dysfunction
abnormality resulting in stenosis or regurgitation of the heart valve substitute that is not intrinsic to the valve itself

NOTE This dysfunction is exclusive of valve thrombosis, systemic embolus or infection diagnosed at re-operation, autopsy or *in vivo* investigation. Examples include entrapment by pannus or suture, paravalvular leak, inappropriate sizing, and significant haemolytic anaemia.

3.35
occluder
component(s) of a heart valve substitute, such as rigid or flexible leaflets, discs, and balls, that move(s) to inhibit backflow

NOTE The occluders of flexible heart valve substitutes are typically called "leaflets" or "cusps".

3.36**operative mortality**

death from any cause during operation or within 30 d of the operation

3.37**outflow tract profile height**

maximum distance that the valve extends axially into the outflow tract in the open or closed position, whichever is greater, measured from the valve structure intended to mate with the top (atrial or aortic side) of the patient's annulus

3.38**pannus**

ingrowth of tissue into the heart valve substitute which may interfere with normal functioning

3.39**paravalvular leak**

clinically or haemodynamically detectable defect between the heart valve substitute and the patient's annulus

NOTE The term "perivalvular" is deprecated.

3.40**probability**

statistical likelihood that a specific event will occur

3.41**process validation**

establishing, by objective evidence, that a process consistently produces a result or product that meets its predetermined specifications

3.42**profile height**

maximal axial dimension of a heart valve substitute in the open or closed position, whichever is greater

3.43**prosthetic valve endocarditis**

infection involving a heart valve substitute

NOTE Diagnosis is based on customary clinical criteria, including an appropriate combination of positive blood cultures, clinical signs (fever, new or altered cardiac murmurs, splenomegaly, systemic embolus or immunopathologic lesions) and/or histologic confirmation of endocarditis at reoperation or autopsy. Morbidity associated with active infection such as valve thrombosis, embolus or paravalvular leak is included under this category and is not included in other categories of morbidity.

3.44**quasi-real time durability testing**

long-term durability testing performed at a cycle rate between normal and high normal (up to 200 cycles/min)

3.45**reference valve**

heart valve substitute used to assess the conditions established in the *in vitro* tests used to evaluate the test heart valve substitute

NOTE The reference valve should approximate the test heart valve substitute in type, configuration and tissue annulus diameter; it may be an earlier model of the same valve, if it fulfills the necessary conditions. The characteristics of the reference valve should be well documented with clinical data.

3.46

regurgitant fraction

regurgitant volume expressed as a percentage of the stroke volume

3.47

regurgitant volume

volume of fluid that flows through a heart valve substitute in the reverse direction during one cycle and is the sum of the closing volume and the leakage volume

See Figure 1.

3.48

rigid heart valve substitute

heart valve substitute wherein the occluder(s) and orifice ring are non-flexible under physiological conditions

NOTE This category was previously known as mechanical heart valve substitute. Materials of construction of the rigid components of rigid heart valve substitutes have historically been metals, pyrolytic carbon and polymers.

3.49

risk

combination of the probability of occurrence of harm and the severity of that harm

[ISO/IEC Guide 51:1999 ^[14], definition 3.2]

3.50

risk analysis

systematic use of available information to identify hazards and to estimate the associated risks

NOTE Adapted from ISO/IEC Guide 51:1999 ^[14], definition 3.10.

3.51

risk assessment

overall process comprising a risk analysis and a risk evaluation

[ISO/IEC Guide 51:1999 ^[14], definition 3.12]

3.52

risk control

process through which decisions are reached and protective measures are implemented for reducing risks to, or maintaining risks within, specified levels

3.53

risk estimation

process used to assign values to the probability and consequences of a risk

3.54

risk evaluation

judgment, on the basis of risk analysis, of whether an acceptable level of risk has been achieved in a given context based on the current values of society

NOTE Adapted from ISO/IEC Guide 51:1999 ^[14], definitions 3.7 and 3.11.

3.55

risk management

systematic application of management policies, procedures and practices to the tasks of analysing, evaluating and controlling risk

3.56**root mean square forward flow****RMS forward flow**

square root of the integral of the volume flow waveform squared

NOTE 1 This is calculated using Equation (1).

$$q_{v \text{ RMS}} = \sqrt{\frac{\int_{t_1}^{t_2} q_v(t)^2 dt}{t_2 - t_1}} \quad (1)$$

where

$q_{v \text{ RMS}}$ is root mean square forward flow;

$q(t)$ is instantaneous flow at time t ;

t_1 is time at start of forward flow;

t_2 is time at end of forward flow.

NOTE 2 The rationale for use of $q_{v \text{ RMS}}$ is that the instantaneous pressure difference is proportional to the square of instantaneous flow rate, and it is the mean pressure difference that is required.

3.57**safety**

freedom from unacceptable risk

[ISO/IEC Guide 51:1999 [14], definition 3.1]

3.58**severity**

measure of the possible consequences of a hazard

3.59**simulated cardiac output**

net fluid volume forward flow per minute, through a test heart valve substitute

3.60**special processes**

those processes for which the product cannot be fully verified by inspection or test

3.61**sterile**

free from viable micro-organisms

3.62**sterility assurance level****SAL**

probability of a viable micro-organism being present on a product after sterilization

3.63**sterilization**

validated process used to render a product free from all forms of viable micro-organisms

3.64**stroke volume**

volume of fluid moved through a test heart valve substitute in the forward direction during one cycle

3.65**structural deterioration**

change in the function of a heart valve substitute resulting from an intrinsic abnormality that causes stenosis or regurgitation

NOTE This definition excludes infection or pannus overgrowth, or thrombosis of the heart valve substitute as determined by reoperation, autopsy or *in vivo* investigation. It includes intrinsic changes such as wear, fatigue failure, stress fracture, occluder escape, calcification, cavitation erosion, leaflet tear and stent creep.

3.66

supra-annular sewing ring

sewing ring designed to secure the valve wholly above the patient's tissue annulus

See Figure 2.

3.67

systemic embolism

clot or other particulate matter, not associated with infection, originating on or near the heart valve substitute and transported to another part of the body

NOTE Diagnosis may be indicated by a new, permanent or transient, focal or global neurologic deficit (exclusive of haemorrhage) or by any peripheral arterial embolus unless proved to have resulted from another cause (e.g. atrial myxoma). Patients who do not awaken post-operatively or who awaken with a stroke or myocardial infarction are excluded. Acute myocardial infarction that occurs after operation is arbitrarily defined as an embolic event in patients with known normal coronary arteries or who are less than 40 y of age.

3.68

tissue annulus diameter

TAD

diameter in millimetres of the smallest flow area within the patient's valve annulus

3.69

validation

confirmation by examination and provision of objective evidence that the particular requirements for a specific intended use can be consistently fulfilled

3.70

valve size

manufacturer's designation of a heart valve substitute which indicates the tissue annulus diameter (TAD in millimetres) of the patient into whom the heart valve substitute is intended to be implanted (i.e., TAD = designated valve size)

NOTE This takes into consideration the manufacturer's recommended implant position relative to the annulus and the suture technique. See also A.7, Q.2.2 c), Q.2.3 b) and Q.2.3 g).

3.71

valve thrombosis

blood clot, not associated with infection, causing dysfunction of the heart valve substitute

NOTE Diagnosis may be proved by operation, autopsy or clinical investigation (e.g. echocardiography, angiocardiography or magnetic resonance imaging).

3.72

verification

confirmation by examination and provision of objective evidence that specified requirements have been fulfilled

4 Abbreviations

For the purposes of this document, the following abbreviations apply.

A_{BS} Body Surface Area

A_{EO} Effective Orifice Area

AF	Atrial Fibrillation
ALARP	As Low As Reasonably Practicable
AWT	Accelerated Wear Testing
BSE	Bovine Spongiform Encephalopathy
CFD	Computational Fluid Dynamics
ECG	Electrocardiogram
ESRD	External Sewing Ring Diameter
FEA	Finite Element Analysis
FMEA	Failure Mode and Effect Analysis
FTA	Fault Tree Analysis
IFU	Instructions For Use
INR	International Normalized Ratio
IOA	Internal Orifice Area
OPC	Objective Performance Criteria
PROB	Probability Rating
RIND	Reversible Ischemic Neurological Deficits
RPN	Risk Priority Number = SEV × PROB
SEV	Hazard Severity Rank
SEM	Scanning Electron Microscopy
TAD	Tissue Annulus Diameter

5 Fundamental requirements

The manufacturer shall determine, at all stages of the product life cycle, the acceptability of the product for clinical use. The requirements of ISO 14971 and ISO 13485 shall apply.

6 Device description

6.1 Intended use

The manufacturer shall identify the physiological condition(s) to be treated, the intended patient population, potential adverse events and intended claims.

6.2 Design inputs

6.2.1 Operational specifications

The manufacturer shall define the operational specifications for the device, including the principles of operation, expected device lifetime, shelf life, shipping/storage limits, and the physiological environment in which it is intended to function. Table 1 defines the expected physiological parameters of the intended patient population for heart valve substitutes for both normal and pathological patient conditions.

Table 1 — Heart valve substitute operational environment

Parameter	Description			
Surrounding medium:	Human heart/Human blood			
Temperature:	34 °C to 42 °C			
Heart rate:	30 beats/min to 200 beats/min			
Cardiac output:	3 l/min to 15 l/min			
Stroke volume:	25 ml to 100 ml			
Blood pressures and resultant pressure loads by patient condition:	Arterial peak systolic pressure mm Hg	Arterial diastolic pressure mm Hg	Differential pressure across closed valve	
			Aortic Δp_A mm Hg	Mitral Δp_M mm Hg
Normotensive	100 to 130	65 to 85	95	115
Hypotensive	60	40	50	60
Hypertensive				
Stage 1 (mild)	140 to 159	90 to 99	123	150
Stage 2 (moderate)	160 to 179	100 to 109	138	170
Stage 3 (severe)	180 to 209	110-119	155	195
Stage 4 (very severe)	> 210	> 120	185	210
Extreme (expected maximum pressure for a single cycle)	300	160	230	300

6.2.2 Performance specifications

6.2.2.1 The manufacturer shall establish (i.e. define, document and implement) the clinical performance requirements of the device and the corresponding device performance specifications. The limits for device performance specifications shall be determined by the manufacturer for the specific heart valve substitute design in light of the intended use and claims to be made for the device. The following list of desired clinical and device-based performance characteristics describe a safe and effective heart valve substitute.

6.2.2.2 Specifications shall be defined in respect of at least the following performance characteristics:

- allows forward flow with acceptably small mean pressure difference;
- prevents retrograde flow with acceptably small regurgitation;
- resists embolization;
- resists haemolysis;
- resists thrombus formation;
- is biocompatible;
- is compatible with *in vivo* diagnostic techniques;
- is deliverable and implantable in the target population;
- remains fixed once placed;

- has an acceptable noise level;
- has reproducible function;
- maintains its functionality for a reasonable lifetime, consistent with its generic class;
- maintains its functionality and sterility for a reasonable shelf life prior to implantation.

6.2.3 Packaging, labelling, and sterilization

The heart valve substitute shall meet the requirements for packaging, labelling, and sterilization contained within Annexes P, Q, and S, respectively.

6.3 Design outputs

6.3.1 General

The manufacturer shall establish (i.e., define, document and implement) a complete specification of the heart valve substitute, including component and assembly-level specifications, accessories, packaging and labelling. Figure 3 presents a generic block diagram of a heart valve substitute. Annex I contains a listing of terms that should be used in describing various valve models. Subclause 6.3.2 provides a listing of examples of typical valve components of some heart valve substitutes.

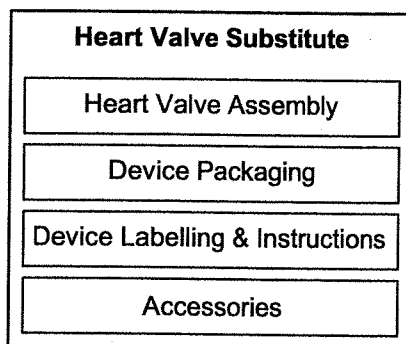

Figure 3 — Generic heart valve substitute block diagram

6.3.2 Examples of components of some heart valve substitutes

The following is a listing of examples of typical valve components of some heart valve substitutes. The following listing is not meant to be exhaustive.

- Coating: any thin-film material that is applied to an element of a heart valve substitute in order to modify its physical or chemical properties;
- component-joining material: material, such as a suture, adhesive or welding compound, used to assemble the components of a heart valve substitute, thereby becoming part of the implant device (see Figures J.1, J.3 and J.4);
- covering: any element applied to enclose any other element of the heart valve substitute (see Figures J.1, J.3, J.4 and J.5);
- occluder/leaflet: component that inhibits backflow (see Figures J.1, J.2, J.3, J.4 and J.5);
- occluder retention mechanism: component(s) of a heart valve substitute which support(s) or retain(s) the occluder(s) (see Figures J.1 and J.2);

- orifice ring (also housing): component of a heart valve substitute that houses the occluder(s) of a rigid heart valve (see Figure J.1);
- sewing ring (also sewing cuff): component of a heart valve substitute by which it can be attached to the heart (see Figure J.1);
- sewing-ring filler: any material within the confines of the sewing ring of the heart valve substitute which provides it with bulk and shape (see Figure J.1);
- sewing-ring retaining material: material used to prevent separation of the sewing ring from the orifice ring or frame (see Figures J.1 and J.2);
- stent (also frame, body): component of a heart valve substitute that houses the occluder(s) of a flexible leaflet device (see Figure J.5);
- stiffening element: component which reduces deformation of the orifice ring or stent (see Figure J.1).

6.4 Design transfer (manufacturing qualification)

6.4.1 The manufacturer shall generate a manufacturing flowchart identifying the manufacturing process operations and inspection steps. The input of all components and important manufacturing materials shall be indicated on the flowchart.

6.4.2 The manufacturer shall document the results of the validation of all special processes and the validation of all process software.

6.4.3 As part of the risk management process, the manufacturer shall establish the control measures and process conditions necessary to ensure that the device is safe and suitable for its intended use. The risk management file shall identify and justify the verification activities necessary to demonstrate the acceptability of the process ranges chosen.

6.4.4 The manufacturer shall establish the adequacy of full-scale manufacturing by validation of the manufacturing process.

NOTE 1 Refer to Global Harmonization Task Force ^[10] for further detail on design input, design output, and design transfer.

NOTE 2 Refer to Global Harmonization Task Force ^[11] for further detail on process validation.

6.5 Risk management

6.5.1 Hazard identification

Subclause 4.3 of ISO 14971:2000 shall apply. The testing and analysis necessary to estimate the risk associated with each hazard shall be determined from information on the nature of the hazard and the corresponding failure modes/causes. In identifying known and foreseeable hazards, particular consideration shall be given to hazards associated with failure modes related to design, manufacturing and human factors for each of the four elements identified in Figure 3. Table B.1 contains a list of potential hazards specific to heart valve substitutes which may serve as the basis for a risk analysis.

6.5.2 Failure mode identification

The second and third columns of Table B.1 provide a listing of potential failure modes that may result in the identified hazard. A given hazard may result from one or more failure modes; likewise, a given failure mode may result in one or more hazards.

6.5.3 Risk estimation

Subclause 4.4 of ISO 14971:2000 shall apply. To facilitate risk estimation for identified hazards, verification and validation testing may be used, as defined by the risk management plan. The testing outlined in Clause 7 serves as a basis for verification and validation test requirements. The last column of Table B.1 contains a list of potential evaluation methods which may facilitate risk estimation through failure mode identification and/or failure probability quantification. This list is not intended to be all-inclusive but rather a representative listing of methods that may be applicable to the specified hazard and failure mode. The rationale explaining how the tests performed facilitate risk estimation for each identified hazard shall be documented in the risk management file.

Examples of risk estimation schemes are given in Annex C.

6.5.4 Risk evaluation

Clause 5 of ISO 14971:2000 shall apply. Since acceptable risk levels may not be specified by applicable standards, the manufacturer shall establish and justify the risk acceptance criteria used. Any identified risk shall be reduced to a level which is "broadly acceptable" or, if that is not feasible, "as low as reasonably practicable" (ALARP).

Examples of risk evaluation schemes are given in Annex C.

6.5.5 Risk control

Clause 6 of ISO 14971:2000 shall apply. The device design and quality assurance requirements, including packaging and labelling specifications, necessary to assure the acceptability of risks, shall be documented in the risk management file.

6.5.6 Risk review

Subclause 7.4.5.2 shall apply. This International Standard requires long-term follow-up of a subset of patients included in the clinical evaluation of the heart valve substitute. The review of post-production information for relevance to device safety shall include evaluating information from the long-term follow-up as well as other sources of information, such as literature reports, reports to regulatory authorities and field experience reports.

7 Verification testing and analysis/Design validation

7.1 General requirements

The manufacturer shall perform verification testing in order to demonstrate that the device specifications result in a heart valve substitute that meets the design specifications (design output meets design input). The test programme shall consist of those tests identified from the risk analysis. The manufacturer shall establish those tests relating to hazards identified from the risk analysis. The protocols shall identify the test purpose, goal, set-up, equipment (specifications, calibration, etc.), test conditions (with a justification of appropriateness to anticipated *in vivo* operating conditions for the device), acceptance criteria, and sample quantities tested.

The manufacturer shall validate the design of the heart valve substitute, its packaging/labelling, and accessories.

7.2 *In vitro* assessment

7.2.1 Test conditions, sample selection and reporting requirements

7.2.1.1 Test conditions and sample selection

7.2.1.1.1 Test specimens shall emulate, as closely as possible, the condition of the finished product as supplied for clinical use, including exposure to the maximum number of recommended sterilization cycles, where appropriate.

7.2.1.1.2 Where emulation of *in vivo* conditions is applicable to the test method, consideration shall be given to those operational specifications given in Table 1 (see 6.2.1). Where applicable, testing shall be performed using a test fluid of isotonic saline, blood, or a blood-equivalent fluid whose physical properties (e.g. specific gravity, viscosity at working temperatures) are appropriate to the test being performed.

7.2.1.1.3 The choice of test fluid will depend on the test goals and methods, as well as on the valve class. The risk assessment shall play a role in the choice of the test fluid.

7.2.1.2 Reporting requirements

Each test report shall include:

- a) the rationale for the test;
- b) identification and description of the sample tested (e.g. batch number);
- c) identification and description of the reference valve(s);
- d) number of specimens tested, and sample size rationale;
- e) detailed description of the test method;
- f) verification that appropriate quality assurance standards have been met (e.g. good laboratory practice);
- g) test results and conclusions.

Statistical procedures, such as the ones described in Annex E, may be used to assist data analysis.

7.2.2 Material property assessment

7.2.2.1 General

Properties of heart valve substitutes and their components shall be evaluated as applicable to the specific design of the valve as determined by the risk assessment.

7.2.2.2 Biological safety

The biocompatibility of the materials and components used in heart valve substitutes shall be determined in accordance with ISO 10993-1. The test plan recorded in the risk management file shall comprise a biological safety evaluation programme with a justification for the appropriateness and adequacy of the information obtained. The documentation shall include a rationale for the commission of any biological safety tests carried out to supplement information obtained from other sources, and for the omission of any tests identified by ISO 10993-1 but not carried out. During the hazard identification stage of a biological safety evaluation, sufficient information shall be obtained to allow the identification of toxicological hazards and the potential for effects on relevant haematological characteristics. Where an identified hazard has the potential for significant clinical effects, the toxicological risk shall be characterized through evaluation of data on, e.g., mode of action, dose-response, exposure level, biochemical interactions and toxicokinetics.

For heart valve substitutes using animal tissue or their derivatives, the risk associated with the use of these materials shall be evaluated in accordance with EN 12442-1, -2 and -3.

7.2.2.3 Material property testing

Material properties of heart valve substitutes and their components shall be evaluated as applicable to the specific design of the valve. Annex D provides potentially relevant physical and chemical properties by material class and components. Annex K provides a list of standards that may be applicable to testing of materials and components.

7.2.3 Hydrodynamic performance assessment

Hydrodynamic testing shall be performed to provide information on the fluid mechanical performance of the heart valve substitute and provide indicators of valve performance in terms of load to the heart and potential for blood stasis and damage.

A guideline for the performing and reporting of hydrodynamic tests is given in Annex L. The detailed protocols shall be based on the findings of the risk assessment.

Tests shall be carried out on at least three heart valve substitutes of each size and on at least one reference valve of each of the small, medium and large sizes. A different sample size or size distribution may be used if it can be shown from the risk analysis that it provides sufficient information.

The *in vitro* test results shall meet or exceed the minimum performance requirements provided in Table 2, which are given as a function of valve size, TAD, and position. The minimum performance requirements correspond to the following pulsatile-flow conditions: beat rate = 70 cycles/min, simulated cardiac output = 5,0 l/min, mean aortic pressure = 100 mm Hg, and systolic duration = 35 %. The minimum performance requirements are based on values in the published scientific literature.

Table 2 — Minimum performance requirements

Position	Aortic							Mitral			
	19	21	23	25	27	29	31	25	27	29	31
Valve size (TAD, mm)	19	21	23	25	27	29	31	25	27	29	31
A_{EO} (cm ²)	≥ 0,70	≥ 0,85	≥ 1,00	≥ 1,20	≥ 1,40	≥ 1,60	≥ 1,80	≥ 1,20	≥ 1,40	≥ 1,60	≥ 1,80
Regurgitant Fraction (%)	≤ 10	≤ 10	≤ 10	≤ 15	≤ 15	≤ 20	≤ 20	≤ 15	≤ 15	≤ 20	≤ 20
NOTE	See Yoganathan and Travis [26] and Marquez et al. [16].										

$$A_{EO} = \frac{q_{v \text{ RMS}}}{51,6 \times \sqrt{\frac{\Delta p}{\rho}}}$$

where

A_{EO} is the effective orifice area in square centimetres;

$q_{v \text{ RMS}}$ is the root mean square forward flow in millilitres per second;

Δp is the mean pressure difference (measured over the positive pressure period of the forward flow phase) in millimetres of mercury;

ρ is the density of the test fluid in grams per cubic centimetre.

NOTE This equation is derived from the Bernoulli Equation. The constant (51,6) is not dimensionless, thus this equation is only valid with the units shown.

7.2.4 Structural performance assessment

7.2.4.1 General

An assessment of the ability of the heart valve substitute to withstand the loads to which it will be subjected shall be performed in order to evaluate the risks associated with potential structural failure modes.

7.2.4.2 Device durability assessment

An assessment of the durability of the heart valve substitute(s) shall be performed in order to assess continued function over a reasonable lifetime. Unless the labelling for a particular device includes an explicit statement about anticipated *in vivo* device lifetime, testing shall be performed to demonstrate reasonable assurance that rigid heart valve substitutes will remain functional for 400 million cycles and that flexible heart valve substitutes will remain functional for 200 million cycles. If the labelling for a particular device includes an explicit statement about anticipated *in vivo* device lifetime, testing shall be performed to support the labelling claim.

Testing shall be performed on at least three each of the largest, medium and smallest sizes of each type (aortic and mitral) of heart valve substitute. One equivalent size reference valve shall be tested under identical conditions for each valve size tested.

Tests shall be performed at a defined differential pressure consistent with normotensive conditions specified in Table 1. During the durability testing, the defined target peak differential pressure across the closed valve shall be maintained for 95 % or more of all the test cycles. Each test valve shall experience a differential pressure equal to or greater than the defined differential pressure for 5 % or more of the duration of each cycle. If aortic and mitral heart valve substitutes are identical in design except for the sewing cuff, testing need only be performed under the differential pressure conditions defined for the mitral valve.

Cycle rates used for accelerated and quasi-real time durability testing should be justified from the results of the risk analysis. Consideration should be given to the behaviour of time-dependent materials when selecting and justifying appropriate cycle rates.

Test valves shall experience the full range of occluder motion associated with normotensive conditions (see Table 1) during testing. Valves undergoing cycling in durability testers shall be observed at regular and frequent intervals (e.g. daily or weekly). Valves shall also be evaluated at intervals of 50 million cycles or less for the duration of the test.

The durability assessment shall be performed by comparison between test and reference valves in terms of the observed damage and the extent of damage and by imposing pass/fail criteria for identified damage. The failure modes to be considered, and the pass/fail criteria for the test shall be determined by the risk assessment.

Additional guidelines for durability testing are given in Annex M.

7.2.4.3 Component fatigue assessment

An assessment of the fatigue performance of the heart valve substitute structural components shall be conducted. The lifetime of each structural component shall be determined as the minimum duration for which the component can withstand anticipated repeated loadings associated with *in vivo* conditions.

The manufacturer shall determine and justify the fatigue assessment approach and associated characterization technique adopted in order to best determine the structural lifetime for the specific material and valve/component design.

Suggested guidelines are provided in Annex O.

Surgery, the *European Journal of Cardiothoracic Surgery* and the *Journal of Cardiovascular and Thoracic Surgery*. The purpose of these guidelines is to facilitate the analysis and reporting of results of operations on diseased cardiac valves. The definitions and recommendations are designed to facilitate comparisons between different surgeons, cohorts, techniques and materials. A heart valve substitute undergoing clinical evaluation should function as intended, with valve complication rates within broadly acceptable performance criteria limits, based on published follow-up studies. To enable appropriate risk assessment, pre-operative, peri-operative and follow-up data should be collated, analysed and reported.

The clinical evaluation of a heart valve substitute after implantation requires documentation of specified complications (see 7.4.7.2); a new or modified heart valve substitute should perform as well or better than existing heart valve substitutes. The clinical evaluation also requires suggested methods of formal statistical evaluation of the clinical data, Objective Performance Criteria (OPC), first year complication rates and Bayesian analysis (see Annex R). Unanticipated valve-related complications should be reported and evaluated prior to the completion of the formal methods of overall performance evaluation.

A.7 Rationale for labelling and instructions for use

Based on past history with replacement heart valves, there have been issues with appropriate sizing and size designations for replacement heart valves which have resulted in confusion among users about which size valve to implant in a particular patient and how to compare published results of one valve model to another. A solution to this problem can be achieved by providing information that more completely encompasses characteristics of valves available today (e.g. sewing ring variations) with the needs of the cardiac surgeon, and ultimately the patient.

To appropriately size a valve the cardiac surgeon needs to know: a) what valve(s) will fit into any given patient and b) which of those valve options will provide the best results. To avoid confusion, the patient's tissue annulus diameter (TAD) should be used as the valve size designation criterion. In other words, if a patient's TAD is measured as 23 mm, that patient could receive a "size 23" valve from any manufacturer, and of any model. Since the position in which the sewing ring is placed and the suturing technique affect the size of valve selected, the valve size provided by the manufacturer should be based on a specific sewing ring configuration and suturing technique that should be identified in the labelling. Using this "patient centered" approach would allow surgeons to accomplish appropriate valve sizing in a straightforward manner. It would then be simple to select a valve size for any given patient and it would allow simple one-to-one comparisons across the spectrum of available valves.

It is recognized that no single uniformly acceptable animal model has been established. Therefore, the animal model selected shall be properly justified in order to ensure the highest degree of human compatible conditions for the test valve and shall be pertinent to the issues being investigated. Since chronic studies are conducted to elucidate biological reactions to the heart valve substitutes in its intended anatomical position, it is necessary to undertake this longer-term testing of the valves in all of the anatomical positions for which it is intended.

The concurrent implantation of control heart valve substitutes enhances the comparative assessment by providing a bridge to known clinical performance. In addition, the distinction between the complications related to the control heart valve substitute versus those of the test heart valve substitute is facilitated.

A.4 Rationale for verification testing

Verification testing includes materials testing, preclinical bench testing, preclinical *in vivo* evaluation and clinical investigations. Although clinical investigations are usually considered to be part of design validation, some of the requirements established under design input may be verifiable only under clinical conditions. The tests specified herein do not purport to comprise a complete test programme; a comprehensive test programme for the heart valve substitute is defined as part of the risk assessment activities. Where the manufacturer's risk assessment concludes that the safety and effectiveness will be better demonstrated by other tests or by modifying the test methods included in this International Standard, the manufacturer shall include in the risk assessment, a justification of the equivalence or superiority of the alternative test or test method.

The manufacturer validates the design of the heart valve substitute, its packaging, labelling and accessories. For a new heart valve substitute, design validation typically occurs in two phases. In the first phase, the manufacturer reviews the results of all verification testing and the manufacturing process validation, prior to the first human implant. The review may also include analysis of the scientific literature, opinions of clinicians and other experts who will be using the device, and comparisons to historical evidence from similar designs. The output of the review should be that the device is safe and suitable for human clinical investigations. The second phase of design validation occurs in conjunction with the end points of the pre-marketing approval of the clinical investigation. The data from the approval phase clinical investigation is reviewed to ensure that the device, its packaging, labelling and accessories are safe and suitable for their intended use and ready for market approval. These validation activities are then documented.

For modification to an existing heart valve substitute design or manufacturing method, the concepts of verification and validation continue to be applicable but may be limited in scope. The scope of the verification and validation is defined by the risk analysis.

The use of clinical grade materials and components, as opposed to generic test samples, is important since fillers, additives and processing aids can have profound implications on material properties. Testing should be designed to evaluate areas where materials are joined (e.g. welded, sutured or glued) since these are potential areas for failure.

A.5 Rationale for Doppler echocardiographic assessment

Two-dimensional echocardiography and Doppler echocardiography are currently accepted as practical and available methods for evaluating human cardiac function and the function of heart valve substitutes. The accuracy of these diagnostic procedures depends upon the skill of the operator. It is recommended that all investigating institutions involved in the clinical evaluation of a specific heart valve substitute use the same echocardiographic protocol.

A.6 Rationale for clinical evaluation reporting

The publication *Guidelines for reporting morbidity and mortality after cardiac valvular operations* has evolved by international consensus, and has been accepted as guidelines to publication by the *Annals of Thoracic*

Annex A **(informative)**

Rationale for the provisions of this International Standard

A.1 Rationale for risk-based approach

The rationale for basing this International Standard on risk management is that the traditional requirements-based model cannot keep up with the speed of technological innovation. With the requirements-based model, manufacturers must spend their time looking for ways to comply with the requirements of the standard, rather than on developing new technologies that may lead to inherently safer products. The risk-based model challenges the manufacturer to continually evaluate known and theoretical risks of the device, to develop the most appropriate methods for reducing the risks of the device, and to implement the appropriate test and analysis methods to demonstrate that the risks have been reduced.

This International Standard combines a requirement for implementing the risk-based model with a listing of best practice methods for verification testing appropriate to heart valve substitute evaluation. The intent of the risk assessment is to identify the hazards along with the corresponding failure modes/causes such that the requisite testing and analysis necessary to evaluate the risk associated with each specific hazard can be identified. The brainstorming/decision making/documentation process that is inherent in risk management provides the opportunity for the manufacturer to evaluate the best practice methods included within this International Standard. The manufacturer may choose to follow the best practice method as defined within this International Standard, deviate from the method, justify why the method is not required, or utilize a different method. These decisions, with rationale, should be documented in the risk management file required by ISO 14971.

The risk-based model requires a collaborative environment between the device developer (the manufacturer) and the body responsible for verifying compliance with the applicable regulation regarding safety and performance of the device. The manufacturer should be striving for continuous improvement in device design as well as test methodologies that can ensure safety and effectiveness of a device with less reliance on years of patient experience for evidence of effectiveness.

A.2 Rationale for material, component and valve assembly testing

The assessment of materials stability is a critical step for achieving long term reliability/performance of heart valve substitutes. This International Standard identifies a series of performance tests that serve as quantitative and qualitative indicators of the stability of materials and/or components used in heart valve substitutes. Some tests are designed to indicate component lifetime, through a durability or fracture mechanics approach. Another test objective is to quantify the functional and safety aspects of heart valve substitutes and to look for potential failure modes. It is the responsibility of the manufacturer to conduct all appropriate material and/or component tests to ensure the safety of the heart valve substitute to a reasonable degree.

A.3 Rationale for preclinical *in vivo* evaluation

The overall objective of preclinical *in vivo* evaluation is to test the function of the heart valve substitute in a biological environment with the closest practically feasible similarity to human conditions.

The preclinical *in vivo* evaluation is the final investigational step prior to human implantation. Therefore, it shall provide the regulatory body with an appropriate level of assurance that the test heart valve substitute will perform at least as well as heart valve substitutes currently in clinical use.

- k) pooling of data from the aortic and mitral positions, generally justified by the fact that short-term morbidity rates are not a significant function of implant position, except for possible early valve thrombosis in the mitral position. The data shall be presented for the entire population, and shall also be stratified by implant position and valve size (TAD).

7.4.7.2 Analysis of complications

The method of reporting shall conform to the *Guidelines for reporting morbidity and mortality after cardiac valvular operations*, 1996 (see Clause 2) and shall include analysis of cause of death and complications using appropriate statistical techniques.

- a) Early complication rates expressed as a percent of patients shall be calculated for events occurring in the first 30 d and again for events occurring in the first year.
- b) Linearized rates shall be used for late complications, with other statistical models as appropriate. Late events are those occurring on the 31st day post implant or later.
- c) Analyses of survival rates and freedom from complication rates using both the actuarial (Kaplan-Meier), and actual (cumulative incidence) methods.

NOTE Standard errors should be reported using Greenwood's algorithm. See Andersen et al. [1].

- d) Specific analyses shall include:

- 1) overall survival;
- 2) survival without valve-related complications;
- 3) freedom from specific complications, including but not limited to valve thrombosis, systemic embolism, anticoagulant-related haemorrhage, prosthetic valve endocarditis, structural deterioration of the heart valve substitute, non-structural dysfunction of the heart valve substitute, paravalvular leak, haemolysis and re-operation.

- e) The specific complications and deaths shall be stratified as follows:

- 1) all complications shall be stratified by valve position and size (TAD);
- 2) thromboembolism shall be stratified by anticoagulation therapy and cardiac rhythm;
- 3) non-structural dysfunction and structural valve deterioration shall be stratified by nature of dysfunction (e.g. thromboembolism, thrombosis, anticoagulant-related haemorrhage, prosthetic valve endocarditis, structural deterioration, non-structural dysfunction, paravalvular leak, haemolysis, and re-operation). Re-operation, explant and any valve-related complication shall be stratified by fatal versus non-fatal events.

The data shall be analysed to determine any effect of valve tissue annulus diameter on complication rates.

7.4.7.3 Performance criteria

Clinical investigation of a heart valve substitute after implantation requires documentation of specified complications (see 7.4.7.2); a new or modified heart valve substitute shall perform as well or better than the complication rates given in Tables R.1 and R.2. Suggested methods for formal statistical evaluation of the clinical data are described in Annex R.

- c) haemodynamic evaluation by Doppler echocardiography (see Annex H for a method);
- d) blood studies, including coagulation profile and tests for haemolysis, red blood count, white blood count, haematocrit, haemoglobin, serum lactate dehydrogenase, haptoglobin and reticulocyte count;
- e) status of anticoagulant and/or antiplatelet therapy at each follow-up visit;
- f) complications, to include thromboembolism, thrombosis, anticoagulant-related haemorrhage, prosthetic valve endocarditis, structural deterioration, non-structural dysfunction, paravalvular leak, haemolysis and reoperation; see 7.4.7.2;
- g) reports of electrocardiograms, chest X-rays and cardiac catheterization, magnetic resonance imaging, if performed;
- h) cardiac rhythm;
- i) re-operation reports;
- j) explant analysis when available; wherever feasible, the explanted test heart valve substitute shall be subjected to appropriate functional, X-ray and histopathological investigations. The investigation protocol shall include detailed instructions for the return of the explanted valves to the manufacturer or an independent laboratory for assessment;
- k) date and cause of death;
- l) autopsy report, if autopsy is performed.

7.4.7 Clinical investigation report

7.4.7.1 General

The report shall tabulate the data collected in 7.4.6 and shall include:

- a) names of the investigators and institutions;
- b) analysis of patient population by age and gender;
- c) comparison of pre-operative and postoperative New York Heart Association functional class;
- d) pre-operative diagnosis of valvular and co-existing disease, operative diagnoses, operative procedures including suture technique, heart valve substitute positioning in relation to the tissue annulus, disc/leaflet orientation, operative complications and subsequent operative procedures;
- e) implant position, type, model, valve size (TAD), tissue annulus diameter of patient and effective orifice area of the heart valve substitute;
- f) number of months since implantation, and method of follow-up (e.g. office, clinic, hospital);
- g) results of haemodynamic evaluation [see 7.4.6.3 e) and 7.4.6.5 c)];
- h) results of blood studies and therapy [see 7.4.6.3 f) and 7.4.6.5 d) and e)];
- i) analysis of complications (see 7.4.7.2);
- j) re-operation reports, explant investigation results, cause and date of death, and autopsy reports;

- b) New York Heart Association functional class;
- c) previous cardiovascular operations [e.g. coronary artery bypass, coronary artery angioplasty, percutaneous valvuloplasty (position), operative valvuloplasty (position), annuloplasty (position), previous heart valve substitute replacement];
- d) other co-existing medical conditions (e.g. liver, kidney and lung disease, substance abuse, diabetes, hypertension and history of endocarditis);
- e) echocardiographic information (see Annex H);
- f) blood studies, including coagulation profile [including prothrombin time, partial thromboplastin time and International Normalised Ratio (INR), as appropriate];
- g) weight, height and body surface area.

7.4.6.4 Peri-operative data

The following data shall be collected:

- a) diagnosis (see 7.4.6.3);
- b) procedure(s), including any concomitant operative procedure(s);
- c) date of operation;
- d) heart valve substitute type, model, valve size (TAD) and serial number;
- e) tissue annulus diameter (TAD) of patient;
- f) suture technique;
- g) retention of all or part (specify) of native valve structures;
- h) implant position (e.g. aortic or mitral), heart valve substitute positioning in relation to tissue annulus (e.g. supra-annular, intra-annular);
- i) heart valve substitute disc/leaflet orientation;
- j) complications, including operative mortality and subsequent operative procedures;
- k) evaluation by echocardiography within 30 d.

7.4.6.5 Follow-up data

Follow-up data shall be collected within 30 d, between 3 and 6 months after implantation of the heart valve substitute, at one year and annually thereafter (see 7.4.5.1) until the investigation is completed. Echocardiography shall be performed at all follow-up assessments unless a risk analysis justifies a less frequent interval.

NOTE Additional follow-up intervals may be appropriate to documenting early or long term structural valve deterioration or non-structural dysfunction.

The following data shall be collected:

- a) date and method of follow-up (e.g. office, clinic or hospital);
- b) New York Heart Association functional class;

7.4.5 Duration of the study

7.4.5.1 One-year follow-up

The clinical investigation shall continue until the minimum number of recipients of each valve type have each been followed for a minimum of 1 y. There must be at least 400 valve years of follow-up of each valve type (e.g. aortic or mitral). All implants shall be analysed, including those patients dying within the first year, and including centres with enrollment below the intended minimum.

7.4.5.2 Long term follow-up

In addition to the one year follow-up on each patient, a long term follow-up evaluation shall be conducted according to the following principles:

- a) the long term follow-up cohort shall be an initially determined subset of the original patients, and shall include a minimum of 150 patients; the selection of the specific patients shall be statistically justified so as to minimize selection bias;
- b) the duration of the long-term study will depend on the risk assessment for the specific device design and/or device modification. Historically, for a rigid heart valve substitute, the follow-up for each patient has extended for a period of five years from the date of implantation. Historically, for flexible heart valve substitutes, the follow-up for each patient has extended for a minimum of 10 y from the date of implantation. The exact period will depend on risk assessment.

7.4.6 Clinical data requirements

7.4.6.1 General

Clinical data specified in 7.4.6.2 to 7.4.6.5 shall be reported for all patients receiving the heart valve substitutes at the institutions referred to in 7.4.3. The clinical study protocol shall be identical for all participating institutions, with the exception of differing national regulatory-related protocol requirements.

All valve-related complications shall be reported to the principal investigator. In addition to the clinical data reporting, adverse events shall be reported promptly, in accordance with national regulations and the reporting requirements of the protocol.

The clinical study shall include appropriate controls, including historical or literature controls, involving a similar type of heart valve substitute in the same position. If literature data are used, these should be from a study published in a peer-reviewed journal during the preceding 5 y.

7.4.6.2 Identifying data

The following data shall be collected:

- a) patient's gender and date of birth;
- b) investigator's name;
- c) name of institution.

7.4.6.3 Pre-operative data

The following pre-operative data shall be collected:

- a) diagnosis (e.g. valvular lesion and etiology) and co-existing cardiovascular diseases (e.g. congestive heart failure, cardiomyopathy, peripheral vascular disease, coronary artery disease, previous myocardial infarction), peripheral vascular operations and cardiac rhythm;

- b) detailed description of the animal model used; the rationale and justification for its use. The pretest health assessment, including any medication given, of each animal shall include documentation of the gender and age of the animal at implantation;
- c) description of the operative procedure, including suture technique, test heart valve substitute orientation, valve position and operative complications;
- d) description of the preoperative and postoperative course of each animal including, clinical observations, medication and clinical condition leading to prescription of each drug. If anticoagulation therapy is used, monitoring data for this treatment [i.e., International Normalised Ratio (INR)];
- e) any significant deviations from the protocol or amendments to the protocol;
- f) names of the investigators and their institutions along with information about the implanting surgeons and the laboratory experience with heart valve implantation and animal handling;
- g) interpretation of data and a recommendation relative to the clinical safety and performance of the heart valve substitute under investigation.

Further details of the test report depend on the defined test protocol.

Guidance on the composition of the test report is given in Annex G.

7.4 Clinical investigation

7.4.1 Principle

Data are obtained on the safety and performance of a heart valve substitute under normal conditions of use in humans; the side effects and related risks of heart valve substitute implantation are documented. The clinical investigation shall include pre-operative, peri-operative and follow-up data from a specified number of patients, each with a minimum of one-year follow-up, to provide statistical justification for the market release of the heart valve substitute.

7.4.2 General

For new heart valve designs, a clinical investigation shall be carried out in accordance with this International Standard. For modification of an existing valve, a clinical investigation shall be considered, based on the results of a risk analysis that evaluates the modification. The clinical investigation shall be conducted in accordance with ISO 14155-1.

7.4.3 Number of institutions

The clinical investigation shall be conducted in a minimum of 8 institutions. The study shall be designed such that the anticipated minimum number of heart valves implanted at any institution shall be 15 of each type (e.g. aortic or mitral) being evaluated.

7.4.4 Number of patients

A minimum number of 150 recipients of isolated aortic heart valve substitutes and a minimum number of 150 recipients of isolated mitral heart valve substitutes shall be evaluated. If the heart valve substitute is intended for implantation in only one position, a minimum of 150 heart valve substitutes shall be evaluated in that position. There shall be a minimum of 15 implants of each valve size of each valve type (e.g. aortic or mitral). Exceptions are: 8 implants of aortic size 19 or smaller; 8 implants of aortic size 29 or larger; 8 implants of mitral size 23 or smaller; 8 implants of mitral size 33 or larger.

The inclusion and exclusion criteria for patient selection shall be clearly established.

NOTE All valve sizes refer to TAD in millimetres.

Specific, minor design modifications of existing and clinically well documented heart valve prostheses may justify omission of animal experimental evaluation if the preclinical outcome can be transferred directly from previous animal experimental evaluations.

7.3.2 Methods

7.3.2.1 General requirements

Guidance on the conduct of *in vivo* preclinical evaluation and a series of tests which can be used to address the relevant issues are given in Annex G. It is recognized that complications arising after valve implantation can be attributed to the implanted valve as well as the environment into which it is implanted — or the interaction between the two. Therefore, complications arising during or after valve implantation must be carefully analysed and interpreted in order to attribute the complication to the valve or the animal or combination of the two.

Implant animals shall be of the same species, and preferably of the same gender and similar age. The test heart valve substitutes shall be assessed in a long term setting in all anatomical positions for which it is intended to be used clinically. Animals suffering from heart valve substitute endocarditis may be excluded from the group of study animals, but the endocarditis event shall be reported.

The number of animals used for implantation of test and control heart valve substitutes shall be justified fully for each test based on the risk analysis.

For long term studies, the duration of the observation period of the animals must be specified according to the parameter(s) under investigation. The observation period shall be appropriately justified in each study protocol, but be no less than 90 d.

In each long term animal test case where a heart valve substitute has been implanted, a macroscopic and histological post-mortem examination shall be performed. Thus, the data shall include information from all animals that have been entered into the study.

If serial blood analysis is performed, sampling shall be made pre-operatively then one week postoperatively then at appropriate intervals during the observation period as well as at termination.

The assessment shall provide at least the following:

- a) any macroscopically detectable pathological consequences (including but not limited to: thromboembolic phenomena, pannus formation, inflammatory reactions) around the heart valve substitute and/or in the major organs;
- b) any macro- or microscopically detectable structural alterations in the heart valve substitute (e.g. cavitation, macroscopic damage, material degeneration, deformation and calcification);
- c) histologic assessment of any thromboembolic material, inflammatory reactions and/or degenerative processes.

7.3.3 Test report

The test laboratory shall produce the test report, which shall include a summary assessment of the data generated during the course of the investigation. The test report shall include the complete study protocol. All data generated from the preclinical *in vivo* evaluation must be incorporated into a comprehensive test report. This includes the results generated by tests described in Annex G.

The test report shall include:

- a) identification of each of the valves used for implantation (product, serial number and other appropriate valve identification);

7.2.4.4 Design specific testing

In order to assess structural failure modes that may not be related to durability or component fatigue, design specific testing may be necessary. In some cases (such as stent creep), design specific testing may have direct implications as to the overall structural lifetime of a component or valve.

Examples of such design specific tests are provided in Annex N.

7.3 Preclinical *in vivo* evaluation

7.3.1 Overall requirements

An appropriate preclinical *in vivo* test programme shall be formulated in order to address relevant valve characteristics specific to the test heart valve substitute.

The preclinical *in vivo* evaluation shall:

- a) reflect the haemodynamic performance of the heart valve substitute as assessed *in vitro*;
- b) provide an assessment of the surgical handling characteristics of the test heart valve substitute and its accessories;
- c) provide data to assess the biological reaction to the heart valve substitute. Consideration should be given but not limited to the following items, as relevant to the specific heart valve substitute under evaluation:
 - 1) healing characteristics (pannus formation, tissue overgrowth);
 - 2) haemolysis;
 - 3) thrombus formation;
 - 4) embolization;
 - 5) foreign body reaction (inflammation, rejection);
 - 6) calcification (flexible valves);
 - 7) acoustic characteristics (rigid valves), if manufacturer claims are made on this issue;
 - 8) structural deterioration and/or non-structural dysfunction;
 - 9) cavitation;
- d) use a test heart valve substitute of clinical quality;
- e) investigate test heart valve substitute in all positions for which it is intended (aortic, mitral, etc.);
- f) subject equally sized control heart valve substitutes to identical test conditions as the test heart valve substitute;
- g) use the same surgical techniques for the implantation of both the test and the control heart valve substitutes (e.g. suture technique and orientation);
- h) be performed by appropriately experienced and knowledgeable test laboratories;
- i) address animal welfare in accordance with the principles given in ISO 10993-2.

Annex B (informative)

Heart valve substitute hazards, associated failure modes and evaluation methods

B.1 Hazards, failure modes and evaluation methods

B.1.1 General

Typical hazards, examples of their associated failure modes, and possible evaluation methods are given in Table B.1. This list is not intended to be all-inclusive but representative of hazards and failure modes that are applicable to heart valve substitutes.

Table B.1 — Heart valve substitute hazards, associated failure modes and evaluation methods

Hazards	Possible failure mode(s)		Possible evaluation methods
	Rigid valve	Flexible valve	
Stenosis	Occluder binding, pannus overgrowth	Pannus overgrowth, leaflet mineralization, excessive stent deformation, stent fracture	Steady/pulsatile-flow pressure difference, stent creep testing, wear/durability testing, fatigue testing/analysis, pre-clinical animal evaluation with echo characterization
Regurgitation	Occluder binding, occluder escape, chipped occluder, chipped orifice, out-of-tolerance condition	Leaflet tear, abrasion, delamination or shrinkage, leaflet prolapse, excessive stent deformation, stent fracture, suture breakage/pull out, suture hole elongation, out-of-tolerance condition	Steady/pulsatile-flow leakage, valve prolapse testing, material characterization, durability testing, fatigue testing/analysis, stent creep testing, device distribution testing, pre-clinical animal evaluation with echo characterization, <i>in vitro</i> flow visualization
Embolization	Occluder fracture, orifice fracture, occluder escape, sewing cuff separation	Leaflet tear, leaflet mineralization, sewing cuff separation	Material characterization, durability testing, fatigue testing/analysis, leaflet blowout/prolapse testing, leaflet escape testing, cavitation testing, device distribution testing
Haemolysis	Cavitation, elevated turbulence	Elevated turbulence	<i>In vitro</i> flow visualization, pre-clinical animal evaluation, clinical evaluation
Thrombosis, thromboembolism	Flow stasis, blood material interaction failure, improper anticoagulation regimen	Flow stasis, blood material interaction failure	Material characterization, <i>in vitro</i> flow visualization, blood material interaction characterization, pre-clinical animal evaluation, clinical evaluation
Bioincompatibility	Local or systemic toxicity, inappropriate tissue response or effect on coagulation, material degradation, leaching of component compounds	Local or systemic toxicity, inappropriate tissue response or effect on coagulation, material degradation, leaching of component compounds	Biocompatibility safety evaluation per applicable ISO standard, material characterization, blood material interaction characterization, biostability testing, corrosion testing, characterization of sterilization residuals, pre-clinical animal evaluation, clinical evaluation

Table B.1 (continued)

Hazards	Possible failure mode(s)		Possible evaluation methods
	Rigid valve	Flexible valve	
Paravalvular leak	Sewing cuff non-compliant, sewing cuff tear, sewing cuff separation, suture breakage/pull out	Sewing cuff non-compliant, sewing cuff tear, sewing cuff separation, suture breakage/pull out	Needle penetration/suture drag characterization, sewing ring integrity testing, durability testing, wet labs, pre-clinical animal evaluation
<i>In vivo</i> diagnostic incompatibility	Device migration, device heating, image distortion, poor device visualization	Device migration, device heating, image distortion, poor device visualization	Material characterization, MRI compatibility testing, radiographic evaluation
Endocarditis	Non-sterile device, non-sterile accessories	Non-sterile device, non-sterile accessories	Validation of sterility processes for device and accessories to a sterility assurance level of 10^{-6} , device package integrity testing
Inability to complete implant procedure; increased operative time	Failure of valve to rotate, improper sizing, valve damaged during handling, device not compatible with accessories	Failure of valve to rotate, improper sizing, valve damaged during handling, device not compatible with accessories	Design validation with device, packaging, accessories and instructions for use; in-process inspections, pre-clinical animal evaluation
Virus, BSE or other transmissible agent	Tissue and/or tissue-derived source material contamination	Tissue and/or tissue-derived source material contamination	Demonstrated compliance with all parts of EN 12442
Bleeding event	Improper anticoagulation regimen	Improper anticoagulation regimen	Clinical evaluation
NOTE This table is given as an example and is not all-inclusive.			

B.1.2 Additional generic failure modes and causes

Additional generic failure modes and causes include:

- sewing cuff defective;
- valve too noisy;
- valve holder broken;
- valve inverted on holder;
- valve cannot be removed from holder;
- instructions for use inadequate;
- inadequate labelling;
- inadequate warnings;
- use by unskilled personnel;
- packaging damaged during shipment;
- shelf life degradation;
- environmental damage during shipment and storage (excess heat or cold);
- improper re-use of device.

Annex C

(informative)

Risk assessment guidelines

C.1 Risk analysis approaches

C.1.1 As there are several risk analysis techniques that may be utilized, no specific technique is specified by ISO 14971, but some techniques are suggested. ISO 14971 notes that the techniques are complementary and it may be necessary to use more than one. This annex describes examples of three complementary approaches to risk analysis which can be applied to the systematic analysis of risks relating to cardiac valve prostheses: hazard analysis, failure mode and effect analysis (FMEA), and fault tree analysis (FTA).

C.1.2 The hazard analysis starts by listing the hazards associated with the given device (e.g. stenosis, regurgitation, embolization, etc.). For each hazard all potential causes are listed. The severity of each hazard is described and the probability of occurrence of the hazard due to the listed cause is estimated. The hazard analysis approach should be applied early in device development, as it will generate the safety requirements for the design. See Table C.5 for an example.

C.1.3 The FMEA starts from the existing design of the device. For each component and assembly, the potential failure modes and corresponding causes are listed along with the resulting failure effects. There may be multiple causes for each failure mode. As in the hazard analysis approach, the severity of the failure effects is described and probability of occurrence of each hazard is estimated for each cause. See Table C.6 for an example.

C.1.4 The FTA provides a logical and orderly description of the various combinations of possible events that may result in a specific adverse event or hazard. The fault tree is an event logic diagram that usually begins with the definition of a top undesired event; the causes are then indicated and connected to the top event by conventional logic gates. The probability of the top event can be predicted using failure probability estimates for each individual event. To augment the FMEA, the FTA can be used to determine root causes.

C.2 Risk estimation

C.2.1 Qualitative method

ISO 14971 notes that risk estimation incorporates the analysis of the probability of occurrence and the consequences or severity for each hazard. The risk estimation examples shown in Table C.1 depict a qualitative approach for combining the severity of the hazard and its probability of occurrence into a descriptive classification scheme. Risk can thus be expressed in a way that can be directly related to the functionality of heart valve substitutes and balanced against benefits derived from their use (see Calman [2] and Tinkler [25]).

Table C.1 — Qualitative risk classification system

Risk classification and classification guides ^a	Description and general examples	Description and examples for heart valves
Negligible Remote, rare or insignificant Less than one in a million	An environmental issue, or consequence of healthcare intervention, of very little concern for daily living; e.g. smoking one cigarette, death by lightning.	Any risk in this category is acceptable for a heart valve; e.g. exploding heart valve.
Minimal Acceptable or very small 1:1 000 000 to 1:100 000	As long as reasonable precautions are taken, the conduct of normal life is not generally affected, although the possibility of a risk is clearly noted; e.g. catching a cold, death by railway accident	Any risk in this category is acceptable for a heart valve; e.g. infection caused by a heart valve substitute.
Very low Unlikely or minor 1:100 000 to 1:10 000	A rate of occurrence comparable with that of adverse effects in many healthcare interventions; e.g. exposure to measles/chicken pox in susceptible children, accidental death at home or at work or playing football.	Risks in this range are normally justifiable by the general benefit arising from valve replacement. Some justification or warning may be prudent; e.g. blood sampling for International Normalized Ratio [INR] monitoring.
Low Reasonable, tolerable or small 1:10 000 to 1:1 000	A rate of occurrence comparable with that of adverse effects in many healthcare interventions; e.g. death by violence, poisoning, influenza or road traffic accident.	Risks in this range should be explained and justified by the benefit arising from valve replacement; e.g. silent embolism, bleeding event.
Moderate 1:1 000 to 1:100	Adverse events can be expected to occur at some time. Health may be significantly affected; e.g. death from all causes at age 40, or from smoking 10 cigarettes per day at any age.	Risks should be justified by a significant benefit arising from heart valve replacement; e.g. valve thrombosis, stroke.
High Significant, frequent, major or serious Greater than 1:100	Adverse effects may be encountered fairly regularly. Possibility of significant deterioration of health; e.g. gastrointestinal effects of antibiotics.	Risks should be justified by a significant benefit arising from the essential need for valve replacement; e.g. prosthetic valve endocarditis.
Unclassified Range unknown or unquantifiable	Not uncommon in the early stages of an environmental concern or a disease process; e.g. BSE infectivity to humans in 1995.	Not uncommon for many hazards potentially arising from medical devices.

^a The risk classification is a combination of severity of hazard and probability of occurrence, for which example descriptors and ranges are given. The numerical range relates to the probability of a major hazard, such as death or serious injury; for less severe hazards probabilities will be higher (see Calman [2]).

C.2.2 Quantitative method

C.2.2.1 General

The risk analysis examples shown in Tables C.5 and C.6 depict the application of probability and severity classifications to quantify the risk associated with identified hazards for generic flexible stented and rigid mechanical valve substitutes utilizing a risk priority number (RPN) approach. Such an approach is not necessary but, since risk analysis for heart valve substitutes is a relatively established and specialized subject, a standardized, quantitative approach to risk analysis can be justified. The inclusion of specific methods in this annex does not obviate the need to verify the suitability of the approach adopted.

C.2.2.2 Probability classification

The probability rating associated with a specific hazard refers to an index that describes the likelihood that the failure mode/cause will occur. The probability rating may be based either on an estimate of probability or on a

descriptive classification. When sufficient data are available, quantitative probability estimates for each identified failure mode/cause combination can be developed. When data to allow quantitative probability estimates are not available, a qualitative approach based on historical information for a similar device may be used.

Tables C.2 and C.3 include example probability classification schemes for identified failure mode/causes. See ISO 14971 for further details.

Table C.2 — Example of qualitative probability classification scheme

Probability rating	Effect	Criteria
7	Very high	Causes happen often
6	High	Causes happen sometimes
5	Moderately high	
4	Medium	Causes happen infrequently
3	Low	
2	Very low	Causes happen rarely
1	Remote	Causes not expected to happen

Table C.3 — Example of quantitative probability classification scheme

Probability rating	Probability of occurrence during device life cycle
7	$> 0,1$
6	$10^{-2} - 0,1$
5	$10^{-3} - 10^{-2}$
4	$10^{-4} - 10^{-3}$
3	$10^{-5} - 10^{-4}$
2	$10^{-6} - 10^{-5}$
1	$< 10^{-6}$

C.2.2.3 Severity classification

As noted in ISO 14971, severity classification makes use of descriptive terms appropriate for the medical device. See ISO 14971:2000, E.2.2 for further details. Table C.4 includes a proposed severity classification scheme to categorize the severity associated with a specific hazard. This table includes categories suitable for heart valve substitutes and examples based upon the clinical history of replacement heart valves. Other probability and severity classification schemes are described in the literature (see Snow [23]).

Table C.4 — Example of hazard severity classification scheme

Effect	Severity rank	Description	Possible hazard/failure mode examples
Catastrophic	7	Probable patient death regardless of intervention	Acute total occlusion of aortic mono-occluder rigid mechanical valve
	6	Probable patient death without immediate intervention	Excessive regurgitation due to escape of occluder from mono-occluder rigid valve
Critical	5	Possible patient death or probable permanent disabling injury regardless of intervention	Excessive regurgitation due to single leaflet escape from bi-leaflet rigid valve
	4	Possible patient death or probable permanent disabling injury without immediate intervention	Prosthetic valve endocarditis
Serious	3	Possible permanent impairment of bodily function	Cerebral embolism from thromboembolism; brachial embolism from thromboembolism
Minor	2	Possible temporary impairment of bodily function	Transient ischemic attack from thromboembolism; loss of memory due to increased operative time
Negligible	1	Slight or no potential for patient injury	Device packaging difficult to open

Table C.5 — Example of a heart valve substitute hazard analysis

Hazard analysis number:		Part name: new flexible stented heart valve substitute design										Prepared by:	
Design/mfg. responsibility:		Part number: 123456										Orig. date:	
Team members:												Rev. date:	
Hazard	Harm	Failure Mode	Potential cause(s)/ mechanism(s) of failure	Prob ^b	Design verification	RPN ^c	Recommended action(s)	Responsibility & target completion date	Action taken	Sev ^a	Prob ^b	RPN ^c	
Excessive regurgitation	Re-op, explant, peripheral edema, dilated cardiomyopathy, hypertrophy		Loads exceed design	1	Stress analysis, clinical data	4							
			Stent bent beyond elastic limit during implantation	2	Stress analysis simulated abuse followed by AWT	8	List precaution in instructions for use, surgeon training						
		Tears or holes in leaflets	Manufacturing flaws	2	Damage tolerance analysis, in-process inspection	8							
			Leaflet abrasion against fabric or suture knots	2	Pulsatile, AWT	8							
			Excessive flexure of leaflets	2	Pulsatile, AWT	8							
				Stent too stiff	2	FEA, pulsatile, AWT	8						

^a Severity rank from Table C.4.

^b Probability rating from Table C.2 or C.3.

^c Risk priority number = severity rank × probability rating.

Table C.6 — Example of a heart valve substitute failure mode and effects analysis (FMEA) — Component approach

FMEA number:										Prepared by:			
Design/Mfg. responsibility:										FMEA orig. date:			
Team members:										FMEA rev. date:			
Part name & number/ function	Failure mode	Potential effects of failure (hazard and/or harm)	Sev ^a	Potential cause(s)/ mechanism(s) of failure	Prob ^b	Design verification	RPN ^c	Recommended action(s)	Responsibility & target completion date	Action taken	Sev ^a	Prob ^b	RPN ^c
Leaflet (occluder) P/N 111111 Stops backward flow, opens in response to fluid flow	Rough surface	Loss of biocompatibility resulting in haemolysis, platelet aggregation, thrombus	4	Wrong specification for surface roughness	1	Compare surface to clinically acceptable samples; surface profilometry, SEM; blood flow loop testing	4						
	Contaminated surface	Loss of biocompatibility resulting in platelet aggregation, thrombus	4	Inadequate production controls	2	Process validation	8						
	Shape of leaflets create poor flow in open position	Turbulent flow resulting in haemolysis, platelet aggregation, thrombus	4	Inadequate cleaning process	2	Characterize surface chemistry, validate cleaning processes	8						
	Fracture	Embolism of small chips resulting in stroke	4	Sharp edges with high stress concentrators	2	CFD, flow visualization Specify appropriate radius of all edges	8						

^a Severity rank from Table C.4.

^b Probability rating from Table C.2 or C.3.

^c Risk priority number = severity rank × probability rating.

C.3 Risk evaluation

Whilst this International Standard does not require that a specific risk evaluation method be used, it does require that it be carried out. ISO 14971 introduces the three-region concept of risk for risk evaluation; the three regions, to be established and justified by the manufacturer, are: intolerable region, "as low as reasonably practicable" (ALARP) region and broadly acceptable region. The region of Figure C.1 appropriate for each risk can be determined by equating the risk estimate (see C.2) with the clinical benefit anticipated from the heart valve, using the established risk acceptance criteria (see 6.5.4). Several risks associated with heart valve substitutes will inevitably be placed in the ALARP region because they have serious consequences and occur reasonably frequently. ISO 14971 requires risk control measures, including warnings for users, to be implemented for such risks.

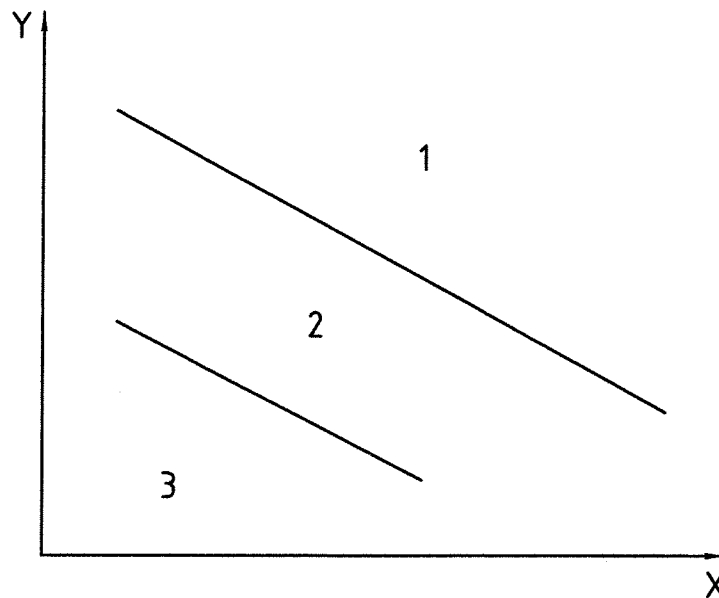
**Key**

- X increasing severity of harm
- Y increasing probability of occurrence
- 1 intolerable region
- 2 ALARP region
- 3 broadly acceptable region

Figure C.1 — Example of a three-region risk acceptability chart
(ISO 14971:2000, E.3)

Annex D **(informative)**

Examples and definitions of some physical and material properties of heart valve substitutes and their components

D.1 General

This annex provides examples of the physical and material properties that may be relevant in characterizing a heart valve substitute and/or its components, and their definitions.

All measurements should be performed on materials or components as they would be found in the finished product. This includes all subsequent treatment after fabrication.

Examples of some standardized test methods that may be relevant for physical and material property characterization are provided in Annex K.

Risk analysis should play a role in the choice of determining the physical and material properties of the heart valve substitute and its components.

D.2 Bulk physical properties

D.2.1 **chemical composition**

identity and possible quantification of an element's composite parts, and its purity, including any processing aids

D.2.2 **density**

mass per unit volume, i.e., the compactness of a material

D.2.3 **liquid diffusivity** **porosity and permeability**

ability of a material to absorb or adsorb biological components from the surrounding tissues and fluid environments

NOTE This biological property may cause calcification and premature failure of some animal tissues under certain stresses.

D.2.4 **material hardness**

resistance to scratching or plastic deformation by indentation

NOTE This is generally related to wear resistance.

D.2.5 **microstructure**

size and shape of the grains, defects, voids, etc. of which the material is composed

NOTE For tissue valves, this should include the cellular or collagen morphology.

D.2.6**coefficient of thermal expansion**

change in physical dimension as a result of a change in temperature

NOTE This property is generally important only for composite parts such as pyrolytic carbon-coated graphite occluders. As the part cools from the deposition temperature of 1 300 °C to room temperature, the coating is submitted to a residual stress, the size and magnitude of which depend on the difference in thermal expansion between the substrate and the coating. This residual stress could affect the strength of the material, the critical flaw size, and crack propagation rates.

D.2.7**glass transition temperature**

characteristic temperature of a polymer system below which long-chain mobility no longer exists

D.2.8**melt index**

number of grams of thermoplastic resin at a specified temperature which can be forced through a specified orifice in an allotted time by a specified pressure

D.2.9**melting point**

temperature at which a solid material turns liquid

D.2.10**hydraulic expansion**

comparison of the dimensions of the material before and after exposure to water

D.2.11**biostability**

measurement of the change in chemical composition of a material after exposure to a physiologic-fluid environment

D.2.12**film thickness**

thickness of a film deposited on a substrate, averaged over the surface of the film

NOTE Techniques for measuring the thickness of thin films include profilometry and ellipsometry. In some cases, Auger depth profiling can be used.

D.2.13**film composition**

elemental composition of a film, expressed as a percentage

D.3 Surface physical properties**D.3.1 General**

All measurements should be performed on materials or components as they would be found in the finished product. This includes all subsequent treatments after fabrication, e.g. sterilization.

D.3.2**critical surface tension**

surface morphology of a biological implant

NOTE Surface roughness and chemical composition play a key role in how an implant interacts with the biological host. Critical surface tension is a useful attribute for characterizing the surface of a solid material. The measurement is affected by the surface's topology, chemistry and cleanliness. The measurements are related to the surface free energy of the material.

D.3.3

surface roughness

microtopology of the component surface

D.3.4

surface chemical composition

material composition within a few atomic layers of the surface

NOTE Variations in the chemicals present at the surface could affect how a material will react with the host. The chemical constituents of the surface can be altered by manufacturing processes such as grinding, polishing, cleaning, sterilizing and handling.

D.3.5

surface charge and surface charge density

type of charge (positive or negative) and the amount that can be bound to the surface of a material

NOTE It has been suggested that surface charge can play an important role in the biocompatibility of materials.

D.3.6

surface resistance

R

ratio of the bulk resistivity and film thickness:

$$R_{\text{sheet}} = \frac{\Omega}{\delta}$$

where

Ω is the bulk resistivity, expressed in ohm-centimetres;

δ is the sample thickness, expressed in centimetres.

NOTE A typical method for determining the sheet resistance is the "four-point probe" method. Such measurements should be done at several places on the surface of the film to obtain an average sheet resistance value.

D.4 Mechanical and chemical engineering properties

D.4.1 General

The following are the materials engineering properties that can be evaluated to assess the ability of a material or a component to function in the intended site.

D.4.2

wear resistance

rate of the systematic removal of material as two surfaces move past one another

D.4.3

coefficient of friction

energy expended in moving two components that are in intimate contact, past one another

D.4.4

peel strength

adhesion between different layers of a material, usually a lamellar composite

NOTE Lamellae could include thin surface layers used to change the chemical boundary conditions of a material.

D.4.5**flexural strength**

stress level required to cause fracture in bending

NOTE There usually is considerable variation in the measured strength among specimens in these tests. To ensure that the data are representative of the true strength of the material, the results should be reported using an appropriate statistical method.

D.4.6**compressive strength**

stress level required to cause fracture in compression

NOTE There usually is considerable variation in the measured strength among specimens in these tests. To ensure that the data are representative of the true strength of the material, the results should be reported using an appropriate statistical method.

D.4.7**tensile strength**

stress level required to cause fracture in tension

NOTE There usually is considerable variation in the measured strength among specimens in these tests. To ensure that the data are representative of the true strength of the material, the results should be reported using an appropriate statistical method.

D.4.8**tensile strain to failure****elongation**

amount of strain or elongation that a material can tolerate just prior to fracture

D.4.9**strain energy to failure**

energy needed to deform a material to the breaking point

NOTE Strain energy is a measure of the toughness of a material, generally in the absence of a durability mechanism.

D.4.10**residual stress**

measurement of the stresses that remain in a material after it has been fabricated

D.4.11**stress relaxation**

gradual change in stress needed to produce specified elongation or deformation

D.4.12**creep**

nonrecoverable change in dimensions of a material under a prescribed mechanical loading condition

D.4.13**fracture toughness**

resistance of a material to crack growth

NOTE It is the stress intensity at which unstable crack growth will proceed.

D.4.14**crack growth velocity**

speed and load conditions under which a crack, once it has been initiated, propagates through a material

NOTE The rates can be influenced by the residual stresses in the material.

D.4.15

fatigue life

number of times a material can be subjected to a load without fracturing

NOTE In general, there are two independent time components to durability failure. First is the crack initiation phase, when repeated loading cycles weaken a material, usually through a defect coalescence process at a flaw site, until a critical flaw size is reached and fracture occurs. Once a crack is initiated, the second, or crack growth, phase of fatigue begins. The crack continues to grow under repeated loading conditions until the stress loading exceeds the fracture toughness, resulting in total failure.

D.4.16

potential stress corrosion

corrosion that could occur or become accelerated as a result of sustained stress, either residual or applied

D.4.17

potential galvanic corrosion

corrosion that could occur between two dissimilar materials

NOTE An example of galvanic corrosion is the reaction between a pyrolytic carbon housing and a titanium stiffening ring.

D.4.18

fretting corrosion

surface damage that occurs between two surfaces that are in close contact, under pressure, and are subjected to slight relative motion

D.4.19

void concentration

number of voids in a film (areas where the film does not cover the substrate) per unit area

NOTE The void concentration is specific to the void size or range of sizes (e.g. a void concentration may be 100 voids of diameter 1 μm or less per square centimetre).

D.4.20

tear strength

force needed to initiate or continue tearing a sheet of fabric

D.4.21

Young modulus

modulus of the elasticity or of the mechanical stiffness of a material

NOTE As a tensile or compressive stress is exerted on a piece of material, it tends to elongate or contract. The ratio of the applied stress to the percentage change in length (strain) is defined as the Young modulus. Young modulus is needed in theoretical modelling of both the static and dynamic stress distributions anticipated in completed devices.

D.4.22

Poisson ratio

ratio of change in dimensions in the transverse direction to those in the longitudinal direction

NOTE When a piece of material is stretched or compressed longitudinally under a uniaxial load, it changes shape transversely. As with the Young modulus, the Poisson ratio is needed to model the mechanical behaviour of completed devices.

D.4.23

dynamic moduli

complex moduli (storage and loss moduli) that describe the mechanical behaviour of viscoelastic materials

Annex E

(informative)

Statistical procedures when using performance criteria

Historically, mean pressure difference and leakage values for a given valve size have been reported as the mean and standard deviation of three samples. This sample size has been criticized for being very small. Small sample sizes are disadvantageous due to large confidence intervals when comparing results to a reference valve or to performance criteria.

The confidence interval can be effectively reduced by modelling the entire experiment, to take into account both the valve size and flow rate (for the pressure difference) or valve size and back pressure (for the leakage). See Stewart and Bushar^[24]. Suitable modelling methods include analysis of variance and regression analysis. Analysis of variance would use the measured parameter (e.g. effective orifice area) as the dependent variable, with the valve size and flow rate (or back pressure) as independent (fixed) factors. Regression analysis models the measured parameter as a function of the valve size and flow rate (or back pressure) taken as numerical values. Either approach may be useful. The performance criteria are then compared to the sample mean plus or minus a confidence interval. Additional information to be reported might include how well the model fits, and the statistical significance of the effects of the size and flow rate (or back pressure).

Annex F (informative)

***In vitro* procedures for testing unstented or similar valves in compliant chambers**

F.1 General

If the pressure difference and/or regurgitation is a function of the compliance of the vessel or chamber into which the valve is to be implanted (e.g. in the case of an unstented aortic valve), then the valve should be tested in compliant chambers as described in F.2. The protocols for pulsatile pressure difference, pulsatile regurgitation and wear/durability should be amended as in F.3.

F.2 Compliant chamber specifications

F.2.1 When testing valves in compliant chambers, consider using two compliant chambers:

- a low compliance chamber for simulating patients with a normal aorta;
- a high compliance chamber for simulating younger patients, or patients with a hypercompliant aorta.

F.2.2 The recommended definition of compliance, over the pulse pressure, to be used in testing and reporting values is:

$$C = 100 \% \times \frac{(d2 - d1)}{d1 (p2 - p1)}$$

where

C is the compliance, $\frac{\%}{\text{kPa}} \left(\frac{\%}{\text{mmHg}} \right)$;

$p1$ is the diastolic pressure, in kilopascals (mm Hg);

$p2$ is the systolic pressure, in kilopascals (mm Hg);

$d1$ is the outside diameter at $p1$, in millimetres;

$d2$ is the outside diameter at $p2$, in millimetres.

F.2.3 Recommended values for the compliance of chambers are:

- low compliance chamber: $C = \frac{0,68\%}{\text{kPa}} \left(= \frac{0,09\%}{\text{mmHg}} \right)$;
- high compliance chamber: $C = \frac{2,40\%}{\text{kPa}} \left(= \frac{0,32\%}{\text{mmHg}} \right)$.

F.2.4 Recommended pressure ranges over which the chamber compliance (without the valve present) should be characterized, and the valves tested, include the hypotensive, normotensive and hypertensive conditions defined in Table 1 (see 6.2.1).

F.3 Test procedures using compliant chambers

F.3.1 Pulsatile-flow pressure difference

Test the valves in the low compliance chamber, under the low, normal and high pressure conditions as defined in Table 1 (see 6.2.1).

F.3.2 Pulsatile-flow regurgitation

F.3.2.1 Test the valves in the low compliance chamber under the low, normal and high pressure conditions as defined in Table 1 (see 6.2.1).

F.3.2.2 Test the valves in the high compliance chamber, under the low and normal pressure conditions as defined in Table 1 (see 6.2.1).

F.3.3 Reference valves for hydrodynamics testing

One small and one large (e.g. 19 mm and 31 mm) currently marketed unstented valves should be used as reference valves in all testing using compliant chambers.

F.3.4 Wear/durability

The valves should be tested in the low compliance chamber.

Annex G (informative)

Preclinical *in vivo* tests

G.1 General

Based on risk analysis and in order to predict the safety and performance of clinical use, a sufficient number of animals should have experimental and control valves implanted. In order to choose the optimal range and extension of tests, it is strongly encouraged that the manufacturer – prior to initiation of *in vivo* testing – submit the proposed protocol for review by any number of internationally recognized experts (provided that there is no conflict of interest) who will provide input relative to the appropriateness of the proposed study design.

The list of tests stated in this annex is representative only, and is not intended to be an all-inclusive list of acceptable tests. Each of the described test procedures includes minimum parameters necessary to assess a specific issue [i.e., to assess haemolysis, a minimum number of specific blood parameters should be obtained (see 7.4)]. However, additional parameters might be relevant depending on specific study goals and/or manufacturer product claims.

As a further specification to risk management (see 6.5), the scheme below (Table G.1) indicates in which settings (acute/chronic) flexible and rigid valves can be evaluated.

Acute testing of heart valve substitutes can be performed under nonsterile conditions and for each of the anatomical positions for which it is intended to be used.

Table G.1 — Settings that can be evaluated

Issue	Acute	Chronic	Flexible	Rigid
Haemodynamic performance	X	X	X	X
Ease of surgical handling	X	X	X	X
Acoustic characteristics	X	X		X
Haemolysis		X	X	X
Thromboembolic complications		X	X	X
Calcification		X	X	
Pannus formation/tissue ingrowth		X	X	X
Structural deterioration and non-structural dysfunction		X	X	X
Assessment of valve and non-valve related pathology		X	X	X
Cavitation		X		X

G.2 Primary parameters

G.2.1 Haemodynamic performance

The haemodynamic measurements should include transvalvular mean pressure. Transvalvular regurgitation measurement should be performed using a continuous flow measurement technique. Multiple measurements of pressure and flow should be obtained.

Transvalvular mean pressure differential and regurgitation should be reported at cardiac index in the range of 3 l/min/m² to 8 l/min/m² minimally on the day of elective euthanasia.

The pressure recording system and the flow meter should have an upper frequency limit (– 3dB cut-off) of at least 30 Hz.

If other measuring equipment is used to assess haemodynamic performance, its performance characteristics should be documented.

G.2.2 Ease of surgical implantation

The ease of surgical implantation should include a descriptive assessment of the surgical handling of the valve and accessories, compared to a control valve including any unusual characteristics.

G.2.3 Acoustic characteristics

The acoustic characteristics of rigid heart valve substitutes should be evaluated in both the aortic and the mitral position. One method of accomplishing this is to use intravascular/intracardiac pressure recordings with a micro-tip pressure transducer that has an upper frequency limit no lower than 20 000 Hz. Air transmitted sound should be recorded 10 cm above the beating heart in the open chest in accordance with IEC 60651 [13]. Alternatively, the valve loudness may be directly measured by applying the Zwicker loudness measurement in accordance with method B of ISO 532:1975 [12] to valve sound recordings taken 5 cm to 10 cm above the closed chest. A technique similar to that described in e.g. Erickson et al. [6] could be used. The acoustic techniques are described in Nygaard et al. [19].

G.2.4 Haemolysis

The following laboratory analyses should be performed: red blood cell count, hematocrit, reticulocyte count, lactate dehydrogenase, thrombocyte count, haptoglobin and plasma haemoglobin.

G.2.5 Thromboembolic complications

Thromboembolic complications should be evaluated in terms of macroscopic description, photographic documentation and a histologic description of any thrombotic material. A full autopsy should be performed to disclose peripheral emboli caused by thrombus formed at the valve prosthesis.

G.2.6 Calcification

Calcification should be evaluated in terms of macroscopic description, photographic documentation and a histologic description of any calcific deposits. Calcification should be further documented using radiographic techniques. The results should be compared to a control valve.

G.2.7 Pannus formation/tissue ingrowth

Pannus formation/tissue ingrowth should be evaluated in terms of macroscopic description including thickness, photographic documentation and a histologic description of any tissue extending beyond the limits of the sewing ring.

G.2.8 Structural valve deterioration and non-structural dysfunction

Structural valve deterioration and non-structural dysfunction should be macro- or microscopically described, evaluated and photographically documented. For bioprosthetic valves, any unused portion of the implanted valve material should be retained in a fixative if deemed appropriate by the programme and/or study director for later additional histo-immunologic studies.

G.2.9 Assessment of valve and non-valve related pathology

Assessment of valve and non-valve related pathology should be macroscopically described, histologically evaluated (if appropriate) and photographically documented.

Visualization of valve function may be appropriate intra- or postoperatively. This can be accomplished by echocardiography, cineangiography, magnetic resonance imaging with or without contrast agents, etc. The performance characteristics of the selected equipment should be documented.

G.2.10 Cavitation

Macro- and microscopic assessment of any signs of erosion caused by cavitation should be documented.

Annex H (informative)

Echocardiographic protocol

H.1 General

H.1.1 Echocardiographic facilities should be equipped with ultrasound systems that have been validated for the intended applications in the assessment of prosthetic heart valves, specifically pulse wave, continuous wave, and colour flow Doppler.

H.1.2 Studies should be performed according to the same protocol. Ideally an investigators' meeting should be conducted before starting the study to resolve questions about the protocol. The echocardiographic protocol should include procedures for assuring the quality of the acquired data.

H.1.3 Studies should be recorded digitally or on tape for review. Central review is utilized primarily to standardize the reporting of semi-subjective measures (e.g., regurgitation) and to ensure uniform quality of data. Data should be reviewed soon after recording a study so that deviations from the protocol can be detected early and, if necessary, a further study can be performed.

H.1.4 Centres should minimize the number of operators performing the protocol-required exams.

H.1.5 Only transthoracic studies are needed routinely. The data from transesophageal studies will also be collected if performed for clinical indications.

H.2 Recording studies

H.2.1 Each study should include the following standard imaging views for B-mode and colour: parasternal long-axis, parasternal short-axis at aortic, mitral and papillary muscle levels, apical 4-chamber, apical 2-chamber, apical long-axis.

H.2.2 Doppler recordings should be made with a stand-alone continuous wave probe from apical views and from additional right intercostal or suprasternal views (for aortic valve replacements).

H.2.3 Subaortic pulsed recordings should be made in the apical 4-chamber view with the sample placed about 0,5 cm to 1 cm below the aortic valve guided by the shape of the waveform to obtain the optimal signal avoiding interference from septum or mitral valve.

H.3 Data collected (by the centre)

H.3.1 Left ventricular dimensions should be collected using either M-mode (ASE leading edge convention), see Sahn et al. [21], or B-mode, whichever is routine for the laboratory. The method should be the same for serial studies in the same patient.

NOTE See Chambers et al. [3]; and Chambers and Shah [4] for further information.

H.3.2 The diameter of the left ventricular outflow tract should be measured on a frame frozen in systole from the trailing edge of the left septal echo to the leading edge of the anterior mitral leaflet echo (largest of three).

H.3.3 From the subaortic waveform (average of 3 in sinus rhythm and 5 in AF): peak velocity, mean pressure difference and velocity integral should be measured.

H.3.4 From the transaortic waveform (aortic valves only) (average of 3 in sinus rhythm and 5 in AF): peak velocity, mean pressure difference, velocity integral, ejection time (measured between the inner margins of the opening and closing artefacts) and RR interval (measured from R wave to R wave on the ECG) should be measured.

H.3.5 The presence and localization of regurgitant jets should be noted. Continuous wave recording with a stand-alone probe should be taken and, at the judgement of the operator, additional recordings, e.g., flow reversal in the aortic arch, should be made.

H.3.6 From the transmitral signal (mitral valves only) (average of 3 in sinus rhythm and 5 in AF): peak velocity, mean pressure difference, velocity integral (DVI), pressure half-time and RR interval should be measured.

H.4 Calculations and analysis (by the core-lab)

H.4.1 Effective orifice area, A_{EO} , can be calculated by the continuity equation:

$$\text{For aortic valves: } A_{EO} = \frac{A_{CS} \times v_{TI1}}{v_{TI2}} \quad (\text{H.1})$$

$$\text{For mitral valves: } A_{EO} = \frac{A_{CS} \times v_{TI1}}{v_{DI}} \quad (\text{H.2})$$

where

A_{EO} is in square centimetres;

A_{CS} is the left ventricular outflow cross-sectional area in square centimetres calculated from the diameter assuming circular cross-section;

v_{TI1} is the subaortic velocity integral in centimetres;

v_{TI2} is the aortic velocity integral in centimetres;

v_{DI} is the diastolic mitral velocity in centimetres.

For aortic valves, the effective orifice area should also be indexed to body surface area:

$$\text{Indexed effective orifice area} = \frac{A_{EO}}{A_{BS}} \quad (\text{H.3})$$

where A_{BS} is the body surface area in square metres.

H.4.2 Peak pressure difference across an aortic valve substitute can be calculated thus:

$$\text{Peak } \Delta p = 4(v_2^2 - v_1^2) \quad (\text{H.4})$$

H.4.3 Mean pressure difference across an aortic valve substitute can be calculated thus:

$$\text{Mean } \Delta p = \text{aortic mean } \Delta p - \text{subaortic mean } \Delta p \quad (\text{H.5})$$

H.4.4 Transaortic flow can be calculated thus:

$$\text{Flow} = 10^3 \times \frac{V_S}{t_{EJ}} \quad (\text{H.6})$$

where

flow is in millilitres per second;

V_S is the stroke volume ($A_{CS} \times v_{TI_1}$, see Equation 1) in millilitres;

t_{EJ} is the ejection time in milliseconds.

H.4.5 Cardiac output:

$$O_C = V_S \times \text{heart rate} \times 10^{-3} \quad (\text{H.7})$$

where

O_C is the cardiac output in litres per minute;

V_S is the stroke volume in millilitres;

heart rate is in beats per minute.

H.4.6 For the left ventricular mass, a number of different methods is available. Despite the greater accuracy of 2-dimensional methods, those based on linear cavity dimensions at the base of the heart remain in common use because they are easy to apply and are effectively sanctioned by an established literature. One approach is to apply the correction of the American Society of Echocardiography (ASE) cube formula suggested by Devereux et al. [5] modified by omitting the final additive constant of + 0,6:

$$\text{LV mass} = 0,83 \times \left[(D_{LVID} + D_{IVS} + D_{PW})^3 - D_{LVID}^3 \right] \quad (\text{H.8})$$

where

LV is left ventricular;

D_{LVID} is the left ventricular internal diastolic diameter in centimetres;

D_{IVS} is the septal diastolic width in centimetres;

D_{PW} is the posterior wall diastolic thickness in centimetres.

Mass should then be indexed to body surface area given by:

$$\text{LV mass index} = \frac{\text{LV}_{\text{mass}}}{A_{BS}} \quad (\text{H.9})$$

H.4.7 For regurgitation, each jet needs to be classified as paraprosthetic, transprosthetic, both or uncertain. The site of paraprosthetic jets can conveniently be marked on a 'clock-face' diagram of the sewing ring. The regurgitation should be graded by a semi-subjective judgment informed by factors including the width of the jet, the shape and density of the continuous wave signal, the activity of the left ventricle and how far diastolic flow reversal can be visualized within the aorta (see Simpson et al. [22]). Of these, the width of the aorta as a proportion of the left ventricular outflow tract diameter is the most frequently-used single measure (see Perry et al. [20]) although it should be applied carefully for eccentric jets.

Annex I (informative)

Description of the heart valve substitute

I.1 General

The description of the heart valve substitute should include, at least, the information listed in Table I.1. The verbal description should be supported by pictures or illustrations where appropriate.

Table I.1 — Information to be included in description of heart valve substitute

Major class	Subclass	Component	Implant position	Annulus position	Orientability
Rigid	Bileaflet	Orifice	Aortic	Supra-annular	Rotatable
	Tilting disc	Occluder	Mitral	Intra-annular	
	Caged ball	Sewing cuff	Tricuspid	Intrasupra-annular	Non-rotatable
	Other		Pulmonic		
Flexible	Stented	Leaflets	Aortic	Supra-annular	Rotatable
	Unstented		Mitral	Intra-annular	
	subcoronary	Stents	Tricuspid	Intrasupra-annular	Non-rotatable
	full root	Sewing cuff	Pulmonic		
	scalloped				

NOTE Components should be described by their material composition (see Annex J).

Example 1: Rigid, tilting disc, PyC occluder with 6-4 titanium orifice, PET/PTFE sewing cuff, aortic and mitral, supra-annular, rotatable.

Example 2: Flexible, stented, bovine pericardial, acetyl copolymer stent, PET sewing cuff, aortic and mitral, supra-annular, non-rotatable.

I.2 Chemical treatments, surface modifications or coatings

The description should include any chemical treatments, surface modifications or coatings used, including primary fixation of tissue and any anti-calcification, anti-infection or anti-thrombotic treatments.

I.3 Component description

Each of the components of the heart valve substitute should be listed and the materials of construction shall be documented. The components list shall include packaging storage media (e.g. for tissue materials). An assembly sketch should be documented that includes all components, including joining materials, such as sutures.

I.4 Implant position

In addition to providing the implant position as listed in Table I.1, a brief description of the implant technique, including procedures for sizing the valve and the recommended suture technique, should be documented.

I.5 Accessories

Any accessories that are to be used in conjunction with the heart valve substitute and its implantation (e.g. sizers, holders) should be described and their materials of construction should be provided.

Annex J
(informative)

Figures of examples of components of some heart valve substitutes

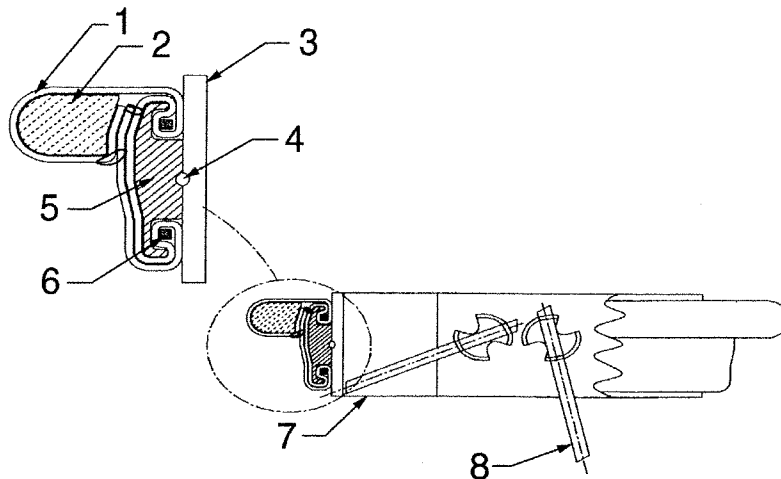

Key

- 1 covering
- 2 sewing ring filter
- 3 orifice ring
- 4 component joining material
- 5 stiffening element
- 6 sewing ring retaining material
- 7 housing
- 8 occluder

Figure J.1 — Generic bi-leaflet rigid heart valve substitute

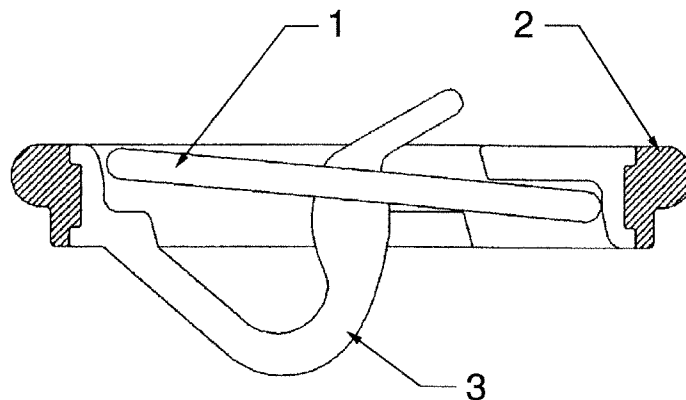

Key

- 1 occluder
- 2 sewing ring retaining material
- 3 occluder retention mechanism

Figure J.2 — Generic mono-leaflet rigid heart valve substitute

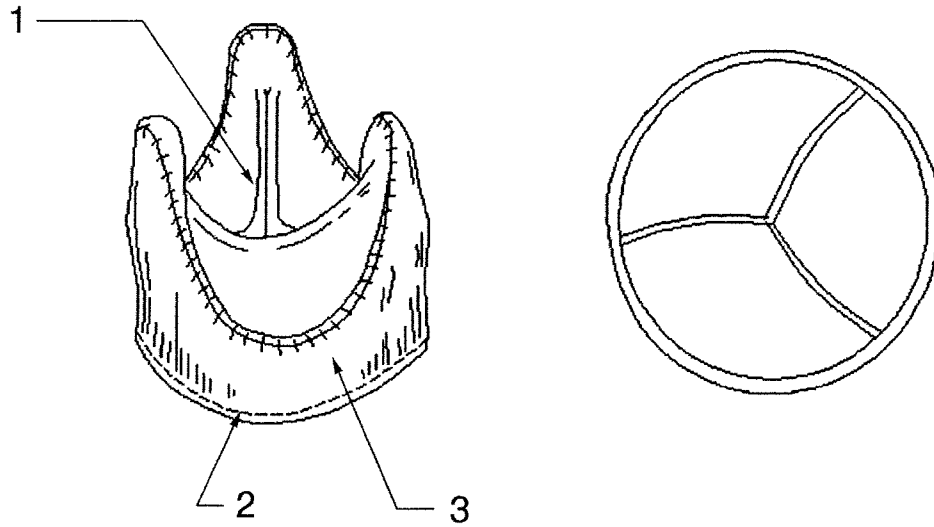

Key

- 1 leaflet
- 2 component joining material
- 3 covering

Figure J.3 — Generic flexible heart valve substitute (flexible, unstented, scalloped)

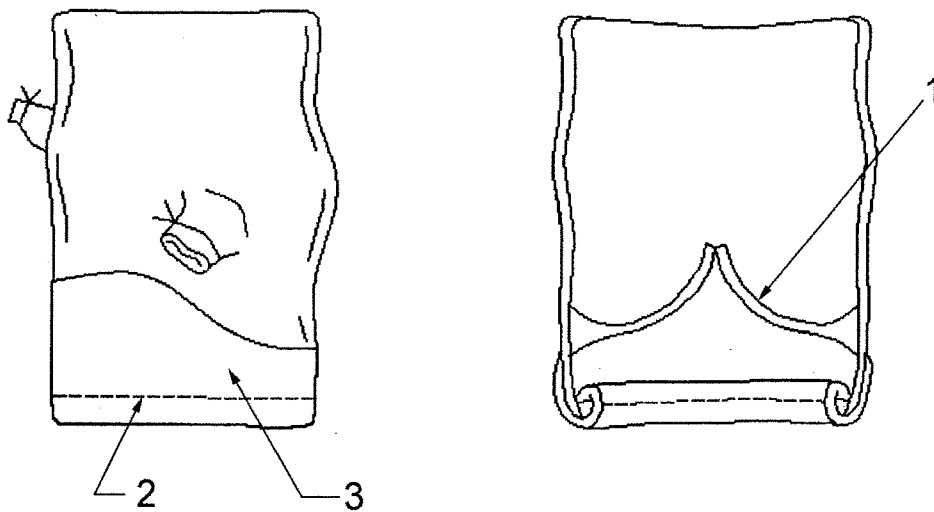

Key

- 1 leaflet
- 2 component joining material
- 3 covering

Figure J.4 — Generic flexible heart valve substitute (flexible, unstented, full root)

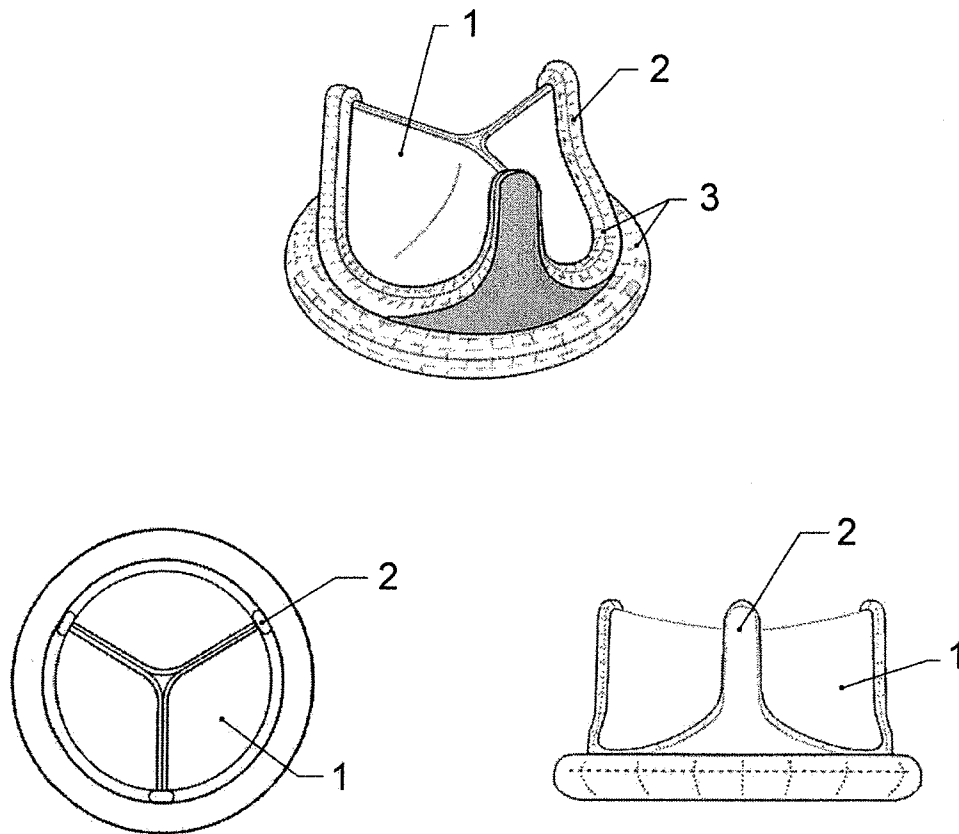

Key

- 1 leaflet
- 2 stent
- 3 covering

Figure J.5 — Generic flexible stented heart valve substitute

Annex K

(informative)

Examples of standards applicable to testing of materials and components of some heart valve substitutes

K.1 Metals

K.1.1 Specifications for materials for metal surgical implants

ISO 5832-1, *Implants for surgery — Metallic materials — Part 1: Wrought stainless steel*

ISO 5832-2, *Implants for surgery — Metallic materials — Part 2: Unalloyed titanium*

ISO 5832-3, *Implants for surgery — Metallic materials — Part 3: Wrought titanium 6-aluminium 4-vanadium alloy*

ISO 5832-4, *Implants for surgery — Metallic materials — Part 4: Cobalt-chromium-molybdenum casting alloy*

ISO 5832-5, *Implants for surgery — Metallic materials — Part 5: Wrought cobalt-chromium-tungsten-nickel alloy*

ISO 5832-6, *Implants for surgery — Metallic materials — Part 6: Wrought cobalt-nickel-chromium-molybdenum alloy*

ISO 5832-7, *Implants for surgery — Metallic materials — Part 7: Forgeable and cold-formed cobalt-chromium-nickel-molybdenum-iron alloy*

ISO 5832-8, *Implants for surgery — Metallic materials — Part 8: Wrought cobalt-nickel-chromium-molybdenum-tungsten-iron alloy*

K.1.2 Tensile test with extensometer to failure

ASTM E 8, *Standard Test Methods for Tension Testing of Metallic Materials*

ASTM E 111, *Standard Test Method for Young's Modulus, Tangent Modulus, and Chord Modulus*

K.1.3 Poisson ratio

ASTM E 132, *Standard Test Method for Poissons Ratio at Room Temperature*

K.1.4 Durability crack initiation and endurance limit; S-N curves

ASTM E 466, *Standard Practice for Conducting Force Controlled Constant Amplitude Axial Fatigue Tests of Metallic Materials*

ASTM E 468, *Standard Practice for Presentation of Constant Amplitude Fatigue Test Results for Metallic Materials*

ASTM E 739, *Standard Practice for Statistical Analysis of Linear or Linearized Stress-Life (S-N) and Strain-Life (ϵ -N) Fatigue Data*

K.1.5 Fatigue crack growth rate; crack growth velocity

ASTM E 647, *Standard Test Method for Measurement of Fatigue Crack Growth Rates*

K.1.6 Hardness

ISO 6507-1, *Metallic materials — Vickers hardness test — Part 1: Test method*

ISO 6508-1, *Metallic materials — Rockwell hardness test — Part 1: Test method (scales A, B, C, D, E, F, G, H, K, N, T)*

K.1.7 Microstructure

ASTM E 3, *Standard Practice for Preparation of Metallographic Specimens*

ASTM E 112, *Standard Test Methods for Determining Average Grain Size*

K.1.8 Thermal expansion

ASTM E 228, *Standard Test Method for Linear Thermal Expansion of Solid Materials With a Vitreous Silica Dilatometer*

K.1.9 Fracture toughness

ASTM E 399, *Standard Test Method for Plane-Strain Fracture Toughness of Metallic Materials*

ASTM E 1820, *Standard Test Method for Measurement of Fracture Toughness*

K.1.10 Fatigue life

ASTM E 466, *Standard Practice for Conducting Force Controlled Constant Amplitude Axial Fatigue Test of Metallic Materials*

ASTM E 468, *Standard Practice for Presentation of Constant Amplitude Fatigue Test Results for Metallic Materials*

ASTM E 648, *Standard Test Method for Critical Radiant Flux of Floor-Covering Systems Using a Radiant Heat Energy Source*

ASTM E 739, *Standard Practice for Statistical Analysis of Linear or Linearized Stress-Life (S-N) and Strain-Life (ϵ -N) Fatigue Data*

K.2 Polymers

K.2.1 Viscosimetry

ASTM D 20, *Standard Test Method for Distillation of Road Tars*

ISO 61, *Plastics — Determination of apparent density of moulding material that cannot be poured from a specified funnel*

K.2.2 Melt flow index

ASTM D 1238, *Standard Test Method for Melt Flow Rates of Thermoplastics by Extrusion Plastometer*

K.2.3 Specifications for high molecular mass polyethylene

ISO 3834-1, *Quality requirements for fusion welding of metallic materials — Part 1: Guidelines for selection and use*

ISO 3834-2, *Quality requirements for fusion welding of metallic materials — Part 2: Comprehensive quality requirements*

ISO 3834-3, *Quality requirements for fusion welding of metallic materials — Part 3: Standard quality requirements*

ISO 3834-4, *Quality requirements for fusion welding of metallic materials — Part 4: Elementary quality requirements*

K.2.4 Determination of breaking strength under static load

ISO 13934-1, *Textiles — Tensile properties of fabrics — Part 1: Determination of maximum force and elongation at maximum force using the strip method*

K.2.5 Tensile test with extensometer to failure (if possible)

ASTM D 638, *Standard Test Method for Tensile Properties of Plastics*

K.2.6 Tensile properties

ISO 527-1, *Plastics — Determination of tensile properties — Part 1: General principles*

ISO 527-2, *Plastics — Determination of tensile properties — Part 2: Test conditions for moulding and extrusion plastics*

ISO 527-3, *Plastics — Determination of tensile properties — Part 3: Test conditions for films and sheets*

ISO 527-4, *Plastics — Determination of tensile properties — Part 4: Test conditions for isotropic and orthotropic fibre-reinforced plastic composites*

ISO 527-5, *Plastics — Determination of tensile properties — Part 5: Test conditions for unidirectional fibre-reinforced plastic composites*

K.2.7 Poisson ratio

ASTM E 132, *Standard Test Method for Poisson's Ratio at Room Temperature*

K.2.8 Determination of dynamic mechanical properties

ISO 6721-1, *Plastics — Determination of dynamic mechanical properties — Part 1: General principles*

ISO 6721-2, *Plastics — Determination of dynamic mechanical properties — Part 2: Torsion-pendulum method*

K.2.9 Resistance to surface wear

ISO 4586-2, *High-pressure decorative laminates — Sheets made from thermosetting resins — Part 2: Determination of properties*

K.2.10 Resistance to scratching

ISO 1518, *Paints and varnishes — Scratch test*

BS 3962-6, *Methods of test for finishes for wooden furniture. Assessment of resistance to mechanical damage*

K.2.11 Flexural properties; determination of breaking strength under dynamic bending load

ISO 178, *Plastics — Determination of flexural properties*

K.2.12 Fatigue crack initiation and endurance limit; S-N curves

ASTM E 466, *Standard Practice for Conducting Force Controlled Constant Amplitude Axial Fatigue Tests of Metallic Materials*

ASTM E 468, *Standard Practice for Presentation of Constant Amplitude Fatigue Test Results for Metallic Materials*

K.2.13 Fatigue crack growth rate

ASTM E 647, *Standard Test Method for Measurement of Fatigue Crack Growth Rates*

K.2.14 Determination of compressive properties

ISO 604, *Plastics — Determination of compressive properties*

K.2.15 Specification of surgical implants made from high-density silicone elastomer

BS 7253-3, *Non-metallic materials for surgical implants. Specification for surgical implants made of heat-vulcanized silicone elastomer*

K.2.16 Density

ASTM E 792, *Standard Guide for Selection of a Clinical Laboratory Information Management System*

K.2.17 Liquid diffusivity (porosity and permeability; water absorption)

ASTM D 570, *Standard Test Method for Water Absorption of Plastics*

K.2.18 Hardness

ASTM D 785, *Standard Test Method for Rockwell Hardness of Plastics and Electrical Insulating Materials*

K.2.19 Wear resistance

ASTM D 1044, *Standard Test Method for Resistance of Transparent Plastics to Surface Abrasion*

ASTM D 4060, *Standard Test Method for Abrasion Resistance of Organic Coatings by the Taber Abraser*

K.2.20 Creep

ASTM D 2990, *Standard Test Methods for Tensile, Compressive, and Flexural Creep and Creep-Rupture of Plastics*

K.2.21 Fracture toughness

ASTM E 399, *Standard Test Method for Plane-Strain Fracture Toughness of Metallic Materials*

ASTM E 1820, *Standard Test Method for Measurement of Fracture Toughness*

K.2.22 Hydraulic expansion

ASTM F 1087, *Standard Test Method for Linear Dimensional Stability of a Gasket Material to Moisture*

K.3 Ceramics and carbons

K.3.1 Physical and chemical properties

ISO 6474, *Implants for surgery — Ceramic materials based on high purity alumina*

K.3.2 Fatigue rate

ASTM E 647, *Standard Test Method for Measurement of Fatigue Crack Growth Rates*

K.3.3 Hardness

ASTM E 92, *Standard Test Method for Vickers Hardness of Metallic Materials*

K.3.4 Thermal expansion

ASTM E 228, *Standard Test Method for Linear Thermal Expansion of Solid Materials With a Vitreous Silica Dilatometer*

K.3.5 Fracture toughness

ASTM E 399, *Standard Test Method for Plane-Strain Fracture Toughness of Metallic Materials*

K.4 Biological materials

K.4.1 Possible adaptation of tensile properties

ISO 527-1, *Plastics — Determination of tensile properties — Part 1: General principles*

ISO 527-2, *Plastics — Determination of tensile properties — Part 2: Test conditions for moulding and extrusion plastics*

ISO 527-3, *Plastics — Determination of tensile properties — Part 3: Test conditions for films and sheets*

ISO 527-4, *Plastics — Determination of tensile properties — Part 4: Test conditions for isotropic and orthotropic fibre-reinforced plastic composites*

ISO 527-5, *Plastics — Determination of tensile properties — Part 5: Test conditions for unidirectional fibre-reinforced plastic composites*

K.5 Textiles

K.5.1 Determination of tear-out resistance

ISO 13937-2, *Textiles — Tear properties of fabrics — Part 2: Determination of tear force of trouser-shaped test specimens (Single tear method)*

K.5.2 Determination of water absorption

DIN 53923, *Testing of textiles; determination of water absorption of textile fabrics*

Annex L (informative)

Guidelines for verification of hydrodynamic performance

L.1 General

This annex provides guidance on test equipment, test equipment validation, formulation of test protocols and test methods for the hydrodynamic performance of heart valves.

L.2 Steady forward-flow testing

L.2.1 Measuring equipment accuracy

L.2.1.1 Pressure measurement system should have a measurement accuracy of at least $\pm 0,26$ kPa (± 2 mm Hg).

L.2.1.2 All other measurement equipment should have a measurement accuracy of at least ± 5 % of the full-scale reading.

L.2.2 Test apparatus requirements

L.2.2.1 Steady flow testing for aortic and mitral heart valve substitutes should be conducted in a straight tube having an internal diameter of 35 mm.

L.2.2.2 The test system should be capable of generating flow rates of at least 30 l/min.

L.2.2.3 Flow entering the test chamber should be relatively non-disturbed; this can be achieved by use of a flow straightener upstream of the heart valve substitute.

L.2.2.4 Pressure taps should be located one tube diameter upstream and three tube diameters downstream from the midplane of the heart valve substitute sewing ring. If sufficient data can be provided to demonstrate comparable results, other pressure tap configurations may be used.

L.2.2.5 Pressure taps should be flush with the inner wall of the tube.

L.2.2.6 A standard nozzle in accordance with Figure L.1 should be used to characterize the forward flow pressure and flow measuring equipment.

L.2.3 Test procedure

Measure the difference across the test valve and the standard nozzle over a flow rate range of 5 l/min to 30 l/min in 5 l/min increments.

L.2.4 Test report

The test report should include:

- a) a description of the fluid used for the test, including its biological origin or chemical components, temperature, viscosity specific gravity;
- b) a description of the steady flow apparatus;

c) details of the mean values and standard deviation of the following performance test variables at each simulated condition for each test heart valve substitute and standard nozzle should be presented in tabular and graphic form:

- 1) steady flow rate;
- 2) pressure differences;
- 3) effective orifice area.

Dimensions in millimetres

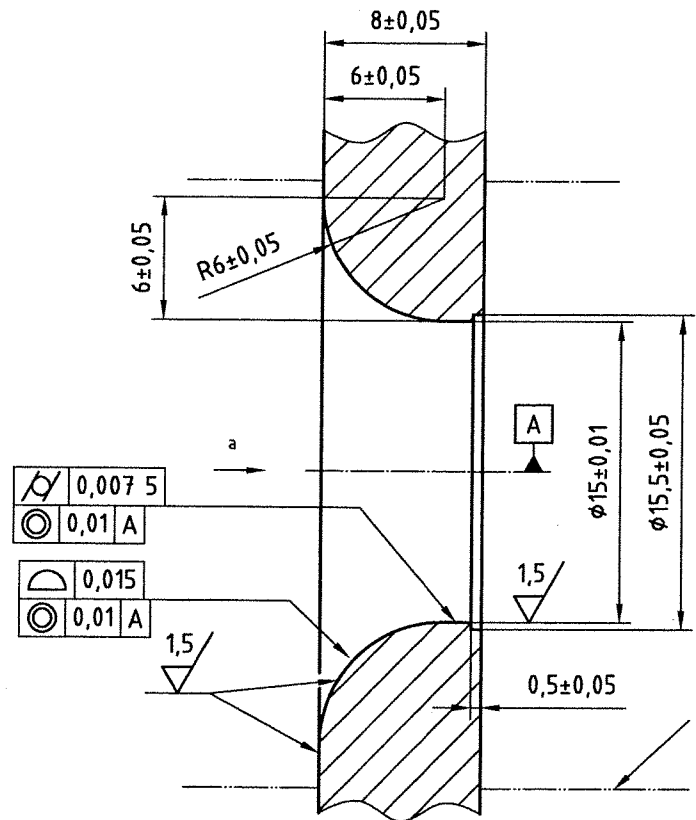

Key

- 1 wall of model vessel
- a Flow direction.

Figure L.1 — Standard nozzle; forward flow

L.3 Steady back-flow leakage testing

L.3.1 Measuring equipment accuracy

L.3.1.1 Steady flow leakage flowrate should have a minimum measurement accuracy of ± 1 ml/s.

L.3.1.2 All other measuring equipment should have a minimum measurement accuracy of ± 5 % of the full-scale reading.

L.3.2 Test apparatus requirements

L.3.2.1 The steady backflow leakage testing should be conducted in an apparatus that is capable of generating constant backpressures in the range of 5,2 kPa to 26 kPa (40 mm Hg to 200 mm Hg).

L.3.2.2 The heart valve substitute should be mounted in such a manner as to minimize leakage around and through the sewing ring.

L.3.2.3 A standard nozzle in accordance with Figure L.2 should be used to characterize the back pressure, leakage volume flow rate and pressure-measuring equipment.

L.3.2.4 The repeatability of the test system should be evaluated and documented.

Dimensions in millimetres

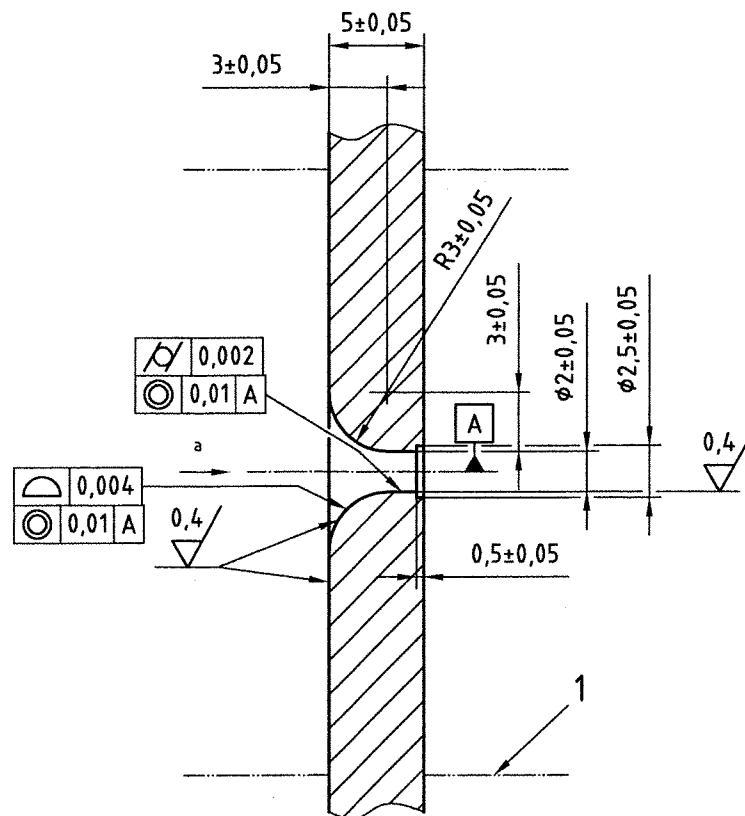

Key

- 1 wall of model vessel
 a Flow direction.

Figure L.2 — Standard nozzle; backflow

L.3.3 Test procedure

Measure the static leakage across the test valve and the standard nozzle at five equidistant back pressures in the range of 5,2 kPa to 26 kPa (40 mm Hg to 200 mm Hg). Collect at least five measurements at each level of back pressure.

L.3.4 Test report

The steady backflow test report should include:

- a) a description of the fluid used for the test, including its biological origin or chemical components, temperature, viscosity and specific gravity under the test conditions;
- b) a description of the steady flow apparatus;
- c) details of the mean, range and standard deviation of the performance test variables, at each simulated condition for each test heart valve substitute and standard nozzle, presented in tabular and graphic form; i.e., static leakage volume flow rate, expressed in l/min, as a function of back pressure.

L.4 Pulsatile-flow testing

L.4.1 Measuring equipment accuracy

L.4.1.1 The pressure measurement system should have a natural frequency of at least 20 Hz and a measurement accuracy of at least $\pm 0,26$ kPa (± 2 mm Hg).

L.4.1.2 Regurgitant volume measurements should have a measurement accuracy of at least ± 2 ml.

L.4.1.3 All other measuring equipment should have a measurement accuracy of at least ± 5 % of the full-scale reading.

L.4.2 Test apparatus requirements

L.4.2.1 Pulsatile-flow testing should be conducted in a pulse duplicator that produces pressure and flow waveforms that approximate physiological conditions over the required physiological range.

L.4.2.2 The pulse duplicator should have had its properties and performance established by means of testing reference valves of different sizes in both the aortic and mitral positions.

L.4.2.3 The pulse duplicator should permit measurement of time-dependent pressures, volumetric flow rates, velocity fields and turbulent shear stress fields.

L.4.2.4 The repeatability of the test system should be evaluated and documented.

L.4.2.5 Relevant dimensions of the cardiac chambers and vessels should be simulated.

L.4.2.6 In cases where the compliance may affect the pressure difference or regurgitation characteristics of the valve (e.g. the aortic compliance in an unstented aortic valve), the relevant chamber compliance should be simulated (see Annex F for guidelines on compliant chambers).

L.4.2.7 The chamber should allow the observer to view and photograph the test heart valve substitute at all stages of the cycle.

L.4.3 Test procedure

L.4.3.1 Tests should be carried out on each valve in the position in which it is intended to be used. Qualitative and quantitative assessments should be made.

L.4.3.2 Pressure difference should be measured at four simulated cardiac outputs between 2 l/min and 7 l/min (e.g. 2 l/min, 3,5 l/min, 5 l/min, 7 l/min), at a single simulated normal heart rate (e.g. 70 cycles/min).

L.4.3.3 Regurgitant volumes should be measured at three different mean (averaged over the cardiac cycle) back pressures [e.g. 10,4 kPa, 15,6 kPa and 20,8 kPa (80 mm Hg, 120 mm Hg and 160 mm Hg)], at three simulated low, normal, and high heart rates (e.g. 45 cycles/min, 70 cycles/min and 120 cycles/min) at a normal simulated cardiac output (e.g. 5 l/min).

L.4.3.4 At least ten measurements of each of the following variables should be obtained from either consecutive or randomly-selected cycles:

- a) mean pressure difference across the test heart valve substitute;
- b) mean and RMS flow rates through the test heart valve substitute;
- c) stroke volume;
- d) cycle rate;
- e) mean arterial pressure over the whole cycle;
- f) duration of forward flow through the test heart valve substitute, as a percentage of cycle time;
- g) regurgitant volume, including the closing volume, the leakage volume (see Figure 1) and the corresponding mean pressure difference across the closed valve.

L.4.3.5 Assess the flow fields (velocity and shear) in the immediate vicinity of the heart valve substitute, including within the valve "housing" mechanism (e.g., within the hinge region of a bileaflet rigid valve design). Techniques for such measurements include laser Doppler velocimetry (LDV), digital particle image velocimetry (DPIV) and computational fluid dynamics (CFD). CFD code should be validated by comparison with experimental results. State-of-the-art CFD techniques should be used to validate the code and its application to the valve design being evaluated.

L.4.3.6 Quantitatively assess the haemolytic and thrombogenic potential of the valve design in each position of intended use, either in the studies described in L.4.3.5, or other relevant *in vitro*, computational and/or *in vivo* studies. Measures such as shear rate magnitude versus duration and particle residence time should be considered.

L.4.4 Test report

The pulsatile-flow test report should include the following information:

- a) a description of the fluid used for the test, including its biological origin or chemical components, temperature, viscosity and specific gravity under the test conditions;
- b) a description of the pulse duplicator, as specified in L.4.2, and its major components and associated apparatus, including a schematic diagram of the system giving the relevant chamber dimensions, chamber compliance (if a compliant chamber is used), details of the location of the pressure-measuring sites relative to the mid-plane of the heart valve substitute sewing ring, pressure measurement instrumentation frequency response, and the appropriate representative pressure and flow waveforms at approximately 70 cycles/min, simulated cardiac output of 5 l/min and mean arterial pressure of 13 kPa (100 mm Hg);
- c) an assessment, including appropriate documentation, of the opening and closing action of a test heart valve substitute and, if appropriate, its adjacent flow field under stated conditions;
- d) a permanent recording of at least ten consecutive or randomly selected cycles of the time-dependent simultaneous pressures, proximal and distal to the heart valve substitute, and the volume flow through it. Details of mean, range and standard deviation of the performance test variables e) to p) at each simulated cardiac output for each test heart valve substitute and reference valve should be presented in tabular and graphic form;

ISO 5840:2005(E)

- e) simulated cardiac output;
- f) cycle rate;
- g) duration of forward-flow phase, expressed as a percentage of the cycle time;
- h) stroke volume;
- i) mean and RMS flow rates;
- j) mean pressure difference;
- k) effective orifice area (provide formula used);
- l) regurgitant volume, closing volume and leakage volume, expressed in millilitres and as a percentage of stroke volume; the corresponding mean pressure difference across the closed valve;
- m) mean arterial pressure over the whole cycle;
- n) appropriate qualitative photographic documentation and quantitative analyses of the opening and closing characteristics for the heart valve substitute;
- o) appropriate documentation and quantitative analyses of the velocity and shear stress fields in the immediate vicinity, including where appropriate within the valve "housing";
- p) appropriate qualitative and quantitative documentation for the haemolytic and thrombogenic potential.

Annex M (informative)

Durability testing

M.1 General

This annex provides guidance on test equipment, formulation of test protocols and test methods for the durability assessment of heart valves. The heart valve substitutes should be tested under appropriate loads while simulating device function in an appropriate fluid environment to a specified number of cycles required to demonstrate *in vitro* device durability. Where test frequency may influence the results of durability tests (e.g., where components are manufactured from viscoelastic materials) quasi-real time testing should be considered.

M.2 Measuring equipment accuracy

The pressure measurement system used to measure the transvalvular pressure difference should have a natural frequency of at least 1 000 Hz and a minimum measurement accuracy of $\pm 0,65$ kPa (± 5 mm Hg) unless otherwise justified.

M.3 Quasi-real time testing

If quasi-real time testing is performed, it should be done under conditions that fall within the range of those specified in Table 1 for a minimum of 80×10^{-6} cycles. The manufacturer should justify the choice of load conditions. It is recommended that a pressure difference of 100 mm Hg or greater should be maintained across the closed valve for at least 20 % of the duration of the cycle.

The results of this testing may be used to evaluate the validity of any accelerated durability test results.

M.4 Results evaluation

Some minor damage is expected on valves after completing durability testing. Failures, however, are characterized by excessive structural damage and/or functional impairment. Examples of structural deterioration include holes, tears, gross delamination, fraying, incomplete coaptation, fracture, excessive deformation, failure of any individual component, other mechanical breakdown and/or wear. Examples of functional impairment include excessive regurgitation and/or excessive transvalvular forward flow pressure difference.

M.5 Report requirements

The durability assessment report should include:

- a) a list of the valves, including reference valves, used to conduct the testing;
- b) justification for the reference valve used;
- c) justification for accelerated and quasi-real time rates used;

ISO 5840:2005(E)

- d) a description of the fluid used for the assessment, including biological origin or chemical components, temperature, viscosity, pH and specific gravity under the simulation conditions;
- e) descriptions, specifications and validations of all test apparatus and references to and/or descriptions of any procedures used in order to complete the assessment;
- f) a list of pertinent test conditions (e.g. cycle rate, average peak closed pressure difference) and rationale for any deviations from those test conditions specified for durability testing;
- g) a detailed description of the appearance of the heart valve substitutes at the completion of the test, at periodic intervals during the test of 50×10^{-6} cycles or less, and upon the development of structural change and/or failure. Any damage should be characterized by using the appropriate means, e.g. histology or surface characterization. It should be indicated if the valves were intact for the length of the evaluation;
- h) the pass/fail criteria and justification for the criteria;
- i) a comparison of the durability results between the test and reference valves.

Annex N

(informative)

Examples of design specific testing

N.1 Sewing ring integrity

This is a measure of the resistance to sewing ring dehiscence. Dehiscence may result from suture failure, suture retention failure, fabric tensile strength failure, fabric weave failure or fabric seam failure.

N.2 Stent creep

An assessment of the potential for structural creep (e.g. polymeric stents) of the heart valve substitute and its structural components should be performed in order to evaluate the risk associated with potential hazards that may be, fully or in part, related to cyclic stent creep.

N.3 Leaflet impingement force

Determination of the maximum radial compressive force (annular load) that can be applied to the valve housing before the housing distorts sufficiently to produce leaflet impingement. Evaluation should consider engineering tolerances of the component features and assembly tolerances. The timing of annular loads and position of the occluder should be considered in the evaluation.

N.4 Leaflet escape force

Determination of the maximum radial compressive force that can be applied to the valve housing before the housing distorts sufficiently to allow leaflet escape. Evaluation should consider engineering tolerances of the component features and assembly tolerances. The timing of annular loads and position of the occluder should be considered in the evaluation.

N.5 Environmental degradation

The degradation resistance of all materials (under stress if appropriate) should be determined in a physiological environment. If cyclic loading is present, tests should be conducted under the same type of loading at a frequency that will not mask any possible forms of localized attack. Final forming methods, such as welding, should be considered.

N.6 Static pressure; “burst” test

A measurement of the hydrostatic load at which failure, e.g. leaflet or orifice fracture or leaflet escape, occurs. For a flexible valve, failure could result in cusp prolapse or tear.

N.7 Sewing ring push-off

A measurement of the strength of the sewing ring attachment to the heart valve substitute.

Particular attention should be paid to the potential for the attachment mechanism to be damaged on insertion.

N.8 Sewing ring torque

This is a measurement of the torque required to rotate the valve within the sewing ring.

N.9 Calcification (*in vivo* model)

This is a measurement of the rate and degree of calcification of the heart valve substitute *in vivo*.

N.10 Leaflet kinematics

Assess the opening and closing kinematics of the occluder of each heart valve substitute under pulsatile-flow conditions (e.g. occluder opening times and characteristics).

N.11 Cavitation

Rigid valves should be assessed for cavitation potential. Cavitation is indicated by the formation of vapour bubbles on valve closure.

Annex O (informative)

Fatigue assessment

O.1 General

A fatigue assessment consists of

- a) a stress analysis of the components/valve under simulated *in vivo* conditions;
- b) a fatigue characterization of the structural material/component;
- c) a fatigue lifetime assessment of the component/valve.

O.2 Stress analysis under simulated *in vivo* conditions

A validated stress analysis of the structural components of the heart valve substitute under simulated *in vivo* conditions should be performed on all structural components. All components of rigid and non-biological flexible valves should be considered. For stented bioprosthetic valves, analysis is only required for the stent component(s), although it may be necessary to include leaflets in the analysis in order to realistically simulate *in vivo* loadings. No analysis is required for unstented bioprosthetic valves.

Stress analyses should be performed on structural components associated with the valve tissue annulus diameter (size) and type (aortic or mitral) in which the highest stresses develop, termed the worst-case size. However, due to differences in component dimensions and/or pressure loading differences between the mitral and aortic positions, the worst-case size may not be the largest size valve and may be specific to each structural component. Thus, while the stress analysis of structural components is only necessary for the worst-case size, it will be necessary to establish this worst-case size for each structural component, which may involve additional stress analysis.

Stress analysis should account for static stresses resulting from differential pressures across the valve and transient stresses occurring during opening and closing (e.g. impact stresses, inertial loadings). The manufacturer should identify and justify the appropriate *in vivo* pressure conditions. Pressures associated with normal, hypertensive and hypotensive conditions in aortic and mitral positions are given in Table 1 (see 6.2.1). The stress analysis should, at a minimum, use pressures associated with normotensive conditions.

Residual stresses resulting from manufacturing processes that were not included in test specimens and any stress concentrations associated with the manufacturing process should be included in the stress analysis.

Valve motion and closure geometry is not always symmetric. This is particularly true for flexible leaflet valves for which geometrical asymmetry may contribute to closure asymmetries. It is important to ensure that the maximum stresses are not underestimated. For this reason, stress analyses should be performed on entire valve/component geometries unless it is demonstrated that the use of a simplified model with symmetry conditions is representative of the full analysis.

An appropriate constitutive model for each material should be used in any stress analysis, including time-dependent and/or nonlinear models as appropriate. Development of constitutive models or evaluation of appropriate constants for existing constitutive models should be based on testing of material that is representative of the actual structural component, including material processing and environmental exposure (e.g. sterilization).

Validation of any stress analysis should be performed in order to demonstrate sufficient confidence in the predicted results. While it is left to the manufacturer to develop and justify such a validation, the validation should include comparisons of predicted and actual experimental measurements. Note that the comparison should be made to independent measurement (i.e., measurements not required to perform the stress analysis prediction).

O.3 Fatigue characterization

O.3.1 General

Fatigue characterization generally falls into three main categories:

- a) stress/life (S/N) for use with classical stress/life assessment;
- b) fatigue crack growth for use in damage tolerance analysis (DTA);
- c) component testing for use in demonstrating fatigue resistance.

The manufacturer should determine and justify the most appropriate characterization and assessment approach for the specific material and valve design. However, the particular characterization technique should be consistent with the subsequent lifetime assessment approach. Fatigue characterization of each structural material/component should be performed to the extent that all properties necessary for the type of fatigue analysis being performed are appropriately determined.

Coupon test specimens used in the determination of material properties should be produced in such a way as to ensure material that is representative of the actual material in the heart valve component (e.g. microstructure, crystallinity, density). Valve components used as test specimens should be representative of actual clinical components (e.g. fabrication methods, defect population). All test specimens should be exposed to all of the environments encountered in clinical valve fabrication.

Fatigue characterization should be performed under loading conditions at least as severe as those *in vivo*. Cyclic test rates/frequencies should be justified by the manufacturer, particularly for materials whose behaviour is rate-dependent (e.g. polymers). Testing should be performed in an environment which is representative of the physiological environment with respect to its effect on fatigue behaviour.

Note that fatigue testing should be performed in such a manner as to preserve the anticipated *in vivo* failure mechanism; e.g., the failure mechanism can undergo transition from ductile to brittle with increased test frequency for some materials such as polymers. Additionally, some materials may experience environmentally assisted degradation in concert with fatigue damage (e.g. stress corrosion). If an accelerated protocol is used (e.g. increased test frequency), the manufacturer should justify its equivalence to *in vivo* loadings.

O.3.2 Stress/life (S/N) characterization

Classical S/N characterization is performed by generating failure data at various cyclic stress levels and/or load ratios in order to determine the maximum permissible stress for a specified design lifetime. While stress has traditionally been used as the operative parameter governing failure, other more appropriate measures (e.g. cumulative strain) may be more relevant for some materials. In such cases, alternate measures should be justified by the manufacturer.

Testing should be performed at a load ratio at least as severe as that experienced *in vivo*, unless otherwise justified. Test frequency and environment, including test temperature and physiologically representative fluid, should be specified and justified by the manufacturer, particularly for time-dependent materials such as polymers and materials that may exhibit environmentally assisted degradation (e.g. corrosion).

Testing should span a sufficient range of stress conditions in order to establish and characterize the fatigue response of the material. This range may extend beyond anticipated *in vivo* loadings. Note that an endurance limit, as classically defined, may not exist for all materials, particularly when exposed to corrosive environments.

O.3.3 Fatigue crack growth (da/dN) characterization

Fatigue crack growth testing is used in association with damage tolerance analyses, which employ a fatigue crack growth relation governing crack propagation from inherent flaws in the material/component. Thus, the fracture toughness and fatigue crack growth behaviour relating the rate of crack growth, da/dN , to an appropriate measure of the cycling crack driving force (commonly taken as the cyclic stress intensity factor, ΔK , although others exist and may be more appropriate depending on material) are determined for the component material.

Fatigue crack growth testing may be performed on test specimens or actual components. In either case, an appropriate measure of the crack driving force should be known, which is why it is often more convenient and common to use more standard fracture specimens whose crack driving force solutions are readily known and available. Because crack growth kinematics depend on the mode of loading (e.g. opening versus shear), testing should also be performed so as to preserve the anticipated *in vivo* mode of crack growth.

Unless plane strain conditions are assured for the test specimen, testing should be performed on specimens whose thickness is at least as thick as the actual component. While machined notches may be used to aid and control the formation of a crack, it may be necessary to pre-crack the specimen prior to generating acceptable crack growth and/or toughness data. However, care should be taken in pre-cracking so as not to overload the specimen. For some materials, like metals, overloads can cause large compressive stresses to develop near cracks, resulting in retarded growth and non-conservative crack growth relations. For the same reason, testing should generally be performed under increasing crack driving force in order to mitigate potential retardation effects.

Testing should span the range of crack driving force from threshold, or minimum anticipated driving force, to near toughness in order to adequately establish and characterize the fatigue crack growth behaviour of the material. Not all materials exhibit threshold behaviour, below which no crack growth occurs. If a threshold is to be used in subsequent damage tolerance analyses, the manufacturer should establish and verify its existence.

O.3.4 Component testing

Fatigue testing of components may be used to demonstrate fatigue lifetimes under conditions that exceed those experienced by the component *in vivo*. Testing should produce stresses (not necessarily displacements) that are representative of and mimic those experienced *in vivo*. Because component testing may only approximate *in vivo* loadings, a validated stress analysis of the component testing may be required to demonstrate that testing is representative of the *in vivo* loadings.

A clear definition of "failure" should be established and be consistent with respect to the specific failure mode(s) identified by the risk analysis. Samples should be characterized and evaluated for failure prior to, during and after testing. Evaluation and documentation periodically during testing should be performed to distinguish fatigue-induced damage from testing artifacts. Testing artifacts should in no way influence the potential for the test to realize fatigue-induced damage.

O.4 Fatigue lifetime assessment

O.4.1 General

A lifetime assessment of the structural components should be performed in order to evaluate risks associated with fatigue-related failure modes. While it is left to the discretion of the manufacturer to determine and justify the most appropriate lifetime assessment approach for the specific material and valve design, the particular approach should be consistent with the appropriate supporting characterization technique. If a general material fatigue characterization (i.e., S/N and fatigue crack growth) has developed, it may be used in fatigue lifetime assessments of several failure modes provided the material data are representative of the material and loadings of each particular failure mode.

O.4.2 Stress-life (S/N) assessment

The S/N structural fatigue life is based on the S/N data in order to determine the predicted lifetime at the maximum stress as determined from the stress analysis. Deterministic or probabilistic approaches may be used for fatigue life assessments. The stress-life assessment should reflect the inherent variability in the fatigue data as well as a measure of confidence in the stress analysis.

The stress-life assessment should identify and account for the effects of permissible variances such as dimensional tolerances and manufacturing-related defects, material variations (e.g. voids, impurities, material property variations), and assess whether the methodologies for assuring variances are maintained within acceptable levels.

O.4.3 Damage tolerance analysis (DTA)

A damage tolerance analysis (DTA) approach is based on the premise that all materials contain defects that may eventually grow to a critical length (defined from the fracture toughness), resulting in failure. The lifetime of a structural component based on a damage tolerance approach is the predicted duration for a minimally detected flaw to grow to failure under *in vivo* conditions. This may require the postulation of initial flaws in critical locations of a component (typically at locations of high stress) and estimates of crack driving forces associated with those locations.

Since the lifetime is a direct function of the initial flaw size, the manufacturer should demonstrate sufficient probability of detecting the minimum flaw size, through inspection and/or proof testing, with appropriate confidence.

In order to perform damage tolerance analyses from fatigue crack growth data generated from fracture specimens, simulated *in vivo* stress analyses should be coupled with fracture mechanics analyses in which validated crack driving forces associated with actual components are obtained. In some cases, more simplified but well-known driving forces may be reasonably used to approximate *in vivo* driving forces (e.g. a crack in a leaflet might be reasonably approximated by a crack in a beam experiencing an equivalent bending load). In such cases, the manufacturer should justify the approximation and include any associated uncertainty in the DTA.

The damage tolerance assessment should identify and account for effects of permissible variances such as dimensional tolerances, material property variations (particularly with respect to fracture/fatigue crack properties and their determination), variations and confidence in identifying initial flaws, and the methodologies for assuring variances are maintained within acceptable levels.

O.4.4 Component demonstration assessment

Component demonstration assessments involve verification that component testing demonstrates sufficient survival with an appropriate confidence level.

Component testing is typically used to demonstrate probability of survival with associated confidence of components subjected to conditions that meet or exceed anticipated *in vivo* conditions. Unless testing is performed under several loading conditions, it may not be possible to extrapolate significantly beyond the duration of the component demonstration testing. As a result, component testing is often used to supplement other lifetime assessments. However, if component testing is performed over a sufficient range of conditions, it may be possible to predict the component lifetime at *in vivo* conditions.

Note that the confidence of the demonstration assessment should reflect the number of components tested and their representation of the actual component population, the ability to detect failures in the test and a measure of confidence in the simulated *in vivo* and test stress analyses.

Annex P (normative)

Packaging

P.1 Requirements

The requirements of Clause 10 of ISO 14630:— shall apply.

P.2 Principle

Packaging shall be designed to ensure that the user is provided with a heart valve substitute whose characteristics and performance are unaltered by normal transit or storage. The packaging shall maintain the characteristics and performance of the package contents under normal conditions of handling, transit and storage, and shall permit the contents to be presented for use in an aseptic manner. There shall be a means to show if the packaging was exposed to abnormal conditions (e.g. freezing, container damage) during transit or storage which could result in damage to the heart valve substitute.

P.3 Containers

P.3.1 Unit container

The heart valve substitute shall be packaged in a unit container that shall be designed so that any damage to the unit container seal is readily apparent. The unit container shall meet the requirements of ISO 11607.

P.3.2 Outer container

The unit container shall be packaged in an outer container (sales/storage package) to protect the unit container.

Annex Q **(normative)**

Labelling and instructions for use

Q.1 Requirements

The requirements Clause 11 of ISO 14630:— shall apply.

Q.2 General

Labelling and instructions for use shall be designed to ensure that the user is provided with information on handling and implanting the heart valve substitute, and a device identification label suitable for use with patient registries.

Q.2.1 Unit-container labelling

Each unit container shall be marked with the following information as specified in Q.2.2 b), c), e), f), g), h), i) and k).

Q.2.2 Outer-container labelling

In addition to applicable storage instructions, each outer container shall be marked with word(s), phrase(s) and/or symbol(s) for:

- a) the contents;
- b) the name or trade-name of the heart valve substitute;
- c) the model, valve size (TAD in millimetres), type and sewing ring configuration of heart valve substitute;
- d) the name/trade-name and address of the manufacturer and/or distributor;
- e) the serial number;
- f) sterile device;
- g) single use device;
- h) sterilization method of the heart valve substitute;
- i) the "Use by" date (year expressed in four digits and month expressed in two digits as specified in 5.2.1.2 of ISO 8601:2000);
- j) a warning against use of the device if the unit container has been opened or damaged;
- k) see instructions/information for use.

Q.2.3 Instructions for use

Each heart valve substitute shall be accompanied by Instructions for Use that shall include at least:

- a) the information contained in Q.2.2 except e) and i). In addition, the size and type in c) "...model, valve size and type...", may be general rather than specific;
- b) the valve dimensions including the valve size dimensions (i.e., external sewing ring diameter, internal orifice area, tissue annulus diameter) and other related dimensions (e.g. profile height, outflow tract profile height);
- c) the indications for use and any known contra-indications;
- d) any warnings regarding handling or implanting the heart valve substitute;
- e) the details of any precautions to be observed, including concomitant procedures or use of other devices (e.g. placing catheters across the valve);
- f) a statement establishing the safety and compatibility of the heart valve substitute with magnetic resonance imaging (MRI). The statement should be based on an analysis of the potential for risk relative to magnetic field interactions, artifacts and/or heating. It should also include the strength of the magnetic field with which the analysis was completed;
- g) a discussion of techniques/instructions for handling and implanting the heart valve substitute. This shall include adequate instructions for appropriate sizing of the valve substitute (utilizing a valve sizer or other method), based on the sewing ring configuration, the patient's tissue annulus diameter and a specified suturing technique;

NOTE Many suture techniques are acceptable but may require modification of the valve sizing method.

- h) a list of potential complications associated with implanted heart valve substitutes;
- i) a description of any accessories required and reference to their instructions for their use;
- j) any recommendations for storage of the heart valve substitute;
- k) instructions for resterilization (if applicable) including the maximum number of resterilization cycles, parameters which have been proven to be capable of achieving sterility of the device, and appropriate information relevant to other methods, apparatus, containers and packaging;
- l) any information or instructions which are intended to be communicated from the physician to the patient;
- m) the manufacturer's name, address, telephone number and other methods of contacting the manufacturer (e.g. facsimile number, e-mail address, etc.). It may be required to have the name and address of either the importer established within the importing country or of an authorized representative of the manufacturer established within the importing country.

Q.2.4 Patient registry label

The manufacturer shall provide peel-off, self-adhesive labels with each heart valve substitute which enable transfer of device information to the appropriate patient registries. Each label shall contain the name or model designation, size and serial number of the heart valve substitute, and manufacturer identification.

The size of the labels shall be sufficient to display the required information in a legible format. Excessive size shall be avoided. The number of required labels may vary based on individual country policies.

Annex R (normative)

Methods of evaluating clinical data

R.1 General

Methods of evaluating clinical data shall include comparing all late complications to objective performance criteria (OPC), comparing events occurring in the first year to tables of first-year complication rates, or Bayesian analysis. It is the responsibility of the manufacturer to propose and justify the specific methodology used.

R.2 Objective performance criteria methodology

Safety and efficacy can be assessed, specifically over the complete timeframe of evaluation, by comparing the occurrence of complications to objective performance criteria (OPC). The OPC are the acceptable rates of valve-related complications as assessed by linearized occurrence rates. The values in Table R.1 may be used in the comparison, without further justification.

Table R.1 — Objective performance criteria for heart valve substitutes

	Rigid	Flexible
Thromboembolism	3,0	2,5
Valve thrombosis	0,8	0,2
All haemorrhage	3,5	1,4
Major haemorrhage	1,5	0,9
All paravalvular leak	1,2	1,2
Major paravalvular leak	0,6	0,6
Endocarditis	1,2	1,2
NOTE Values are in % per valve-year. Data were produced from rigid and flexible valves. See Grunkemeier et al. ^[8] .		

The formal statistical test is that the observed rates must be significantly less than $\times 2$ the OPC.

The rates in Table R.1 were established by the United States Food and Drug Administration after a review of the literature. For events with an OPC of 1,2 %, if the rate equals the OPC, a sample size of 800 valve years will furnish approximately 80 % power for satisfying the formal statistical test (see Grunkemeier et al. ^[8]). If in the same circumstance the rate is 2/3 of the OPC, a sample size of 400 valve years will also furnish approximately 80 % power. It is the responsibility of the manufacturer to propose a trial design that has adequate power, based on a risk analysis of the valve being tested.

R.3 Analysis of first year complication rates

All complications occurring within one year post-implant shall be considered. The complication rates (numbers) in Table R.2 are percentage incidence of complications at 1 year follow-up of the study valves in each position from a large series of heart valve substitutes (see Jamieson et al. [15]). The values in Table R.2 may be used in the comparison, without further justification.

It is the responsibility of the manufacturer to propose specific statistical methodology for comparing rates from the investigation against the rates in Table R.2. The proposal must include a computation of the statistical power, in relation to the number of patients proposed for the investigation.

Table R.2 — First year complication rates (percentages)

Complication	Aortic (flexible)	Aortic (rigid)	Mitral (flexible)	Mitral (rigid)
Structural valve deterioration	0,03	0,00	0,12	0,00
Thromboembolism (Major, RIND)	2,06	2,78	2,48	2,63
Valve thrombosis	0,10	0,00	0,19	0,61
Anticoagulant-related haemorrhage	0,45	2,44	0,80	1,95
Prosthetic valve endocarditis	0,59	0,93	0,68	0,54
Nonstructural valve dysfunction/paravalvular leak	0,38	0,84	1,05	1,75
Re-operation	0,77	1,09	1,05	1,95

NOTE Complication rates were derived from Jamieson et al. [15]. The data were compiled from University of British Columbia patients receiving valve replacements from January 1st, 1982 to December 31st, 1999: 6 738 patients, a total of 7 186 implants, and 4 086 complications.

R.4 Bayesian analysis

The manufacturer may propose a Bayesian analysis for analysing complication rates. It is the responsibility of the manufacturer to propose a specific Bayesian model, including the prior distribution. The sample size for the investigation needs to be justified in relation to the proposed analysis.

Annex S
(normative)

Sterilization

The requirements of Clause 9 of ISO 14630:— shall apply, together with the following.

The contents of the unit container that houses the heart valve substitute shall be supplied sterile. Sterilization shall occur by an appropriate method and shall be validated in accordance with internationally recognized criteria, as given in ISO 11134, ISO 11135, ISO 11137, ISO 14160 and ISO 14937. If the manufacturer states that the heart valve substitute can be re-sterilized prior to implantation, adequate instructions shall be provided by the manufacturer, including parameters that have been proven to be capable of achieving sterility of the device.

Bibliography

- [1] ANDERSEN, P.K., BORGAN, O., GILL, R.D. and KEIDING, N., *Statistical Models based on Counting Processes*, Springer-Verlag, New York, 1993
- [2] CALMAN, K.C., Cancer: science and society and the communication of risk, *Brit Med J.*, 1996, **313**, pp. 799-802
- [3] CHAMBERS, J., FRASER, A., LAWFORD, P., NIHOYANNOPOULOS, P. and SIMPSON I., Echocardiographic assessment of artificial heart valves: British Society of Echocardiography position paper, *Brit Heart J.*, 1994, **71** (suppl), pp. 6-14
- [4] CHAMBERS, J.B. and SHAH, P., Recommendations for the echocardiographic assessment of replacement heart valves, *J Heart Valve Dis*, 1995, **4**, pp. 9-13
- [5] DEVEREUX, R.B., ALONSO, D.R., LUTAS, E.M., GOTTLIEB, G.J., CAMPO, E. et al., Echocardiographic assessment of left ventricular hypertrophy: comparison to necropsy findings, *Am J. Cardiol.*, 1986, **57**, pp. 450-8.
- [6] ERICKSON R. et al., An *In Vitro* Study on Mechanical Heart Valve Sound Loudness, *J. Heart Valve Dis*, 1994, **3**, pp. 330-334
- [7] GRUNKEMEIER, G.L., LI, H.-H., NAFTEL, D.C., STARR, A. and RAHIMTOOLA, S.H., Long-term Performance of Heart Valve Prostheses, *Current Problems in Cardiology*, 2000, **25** (2), pp. 73-156
- [8] GRUNKEMEIER, G.L., JOHNSON, D.M. and NAFTEL, D.C., Sample size requirements for evaluating heart valves with constant risk events, *J. Heart Valve Dis*, 1994, **3**, pp. 53-58
- [9] GRUNKEMEIER, G.L., JAMIESON, W.R.E., MILLER, C.D. and STARR, A., Actuarial versus actual risk of porcine structural valve deterioration, *J. Thoracic and Cardiovascular Surgery*, **108**, pp. 709-718, 1994
- [10] Global Harmonization Task Force, *Design Control Guidance for Medical Device Manufacturers*, June 29, 1999
- [11] Global Harmonization Task Force, *Process Validation Guidance*, June 29, 1999
- [12] ISO 532:1975, *Acoustics — Method for calculating loudness level*
- [13] IEC 60651:1973, *Recommendations for impulse sound level meters*, publication 179 A
- [14] ISO/IEC Guide 51:1999, *Safety aspects — Guidelines for their inclusion in standards*
- [15] JAMIESON, W.R.E., BURR, L. H., ANDERSON Jr., W.N., CHAMBERS, J., GAMS and J., DOWD, C., First year incidence of valve-related complications after aortic and mitral replacement surgery, *J. Heart Valve Dis*, 2002, **11**, pp. 758-763
- [16] MARQUEZ, S., HON R.T. and YOGANATHAN A.P., Comparative hydrodynamic evaluation of bioprosthetic heart valves, *J. Heart Valve Dis* 2001, **10**, pp. 802-811
- [17] MIL-STD-1629A, U.S. Department of Defence Military Standard, *Procedures for performing a failure mode, effects and criticality analysis*, 24 November 1980
- [18] *Miller-Keane Encyclopedia & Dictionary of Medicine, Nursing, Allied Health*, 6th Edition, 1997, W.B. Saunders Company, Philadelphia, PA
- [19] NYGAARD, H. et al., Assessment of perceived mechanical heart valve sound level in patients, *J. Heart Valve Dis*, 1999, **8**, pp. 655-661

- [20] PERRY, G.J., HELMCKE, F., NANDA, N.C. et al., Evaluation of aortic insufficiency by color Doppler flow mapping, *J Am Coll Cardiol*, 1987, **9**, pp. 952-959
- [21] SAHN, D.J., DE MARIA, A., KISSLO, J. and WEYMAN, A.E., The Committee on M-mode Standardization of the American Society of Echocardiography: recommendations regarding quantitation in M mode echocardiography: results of a survey of echocardiographic measurements. *Circulation*, 1978, **58**, pp. 1072-1081
- [22] SIMPSON, I.A., DE BELDER, M.A., KENNY, A., MARTIN, M. and NIHOYANNOPOULOS, P., How to quantitate valve regurgitation by echo Doppler techniques, *Brit Heart J.*, 1995 (Suppl 2), pp. 1-9
- [23] SNOW, A., Integrating risk management into the design and development process, *Med Device Diagn Ind*, March 2001
- [24] STEWART, S.F.C. and BUSHAR, H.F., Improved statistical characterization of prosthetic heart valve hydrodynamics using a performance index and regression analysis, *J. Heart Valve Dis*, 2002, **11**, pp. 270-274
- [25] TINKLER J.J.B., *Biological safety and European medical device regulations*. Quality First International Press, London, 2000
- [26] YOGANATHAN, A.P. and TRAVIS, B., Fluid dynamics of prosthetic valves, In: *The practice of Clinical Echocardiography*, 2nd Edition, 2002, W.B. Saunders Company, Philadelphia, PA

